

Installation Manual

SSB RADIOTELEPHONE

FS-1570 (150 W)/FS-2570 (250 W)

SAFETY INSTRUCTIONS.....	i
SYSTEM CONFIGURATIONS.....	ii
EQUIPMENT LIST.....	iv
1. MOUNTING.....	1-1
1.1 Control Unit.....	1-1
1.2 Antenna Coupler.....	1-3
1.3 Transceiver Unit.....	1-8
1.4 Handset (w/bracket).....	1-9
1.5 Antenna.....	1-9
1.6 Mounting of Optional Equipment.....	1-11
2. WIRING.....	2-1
2.1 Wiring.....	2-1
2.2 External Equipment.....	2-5
2.3 Connection of AC-DC Power Supply Unit (option).....	2-9
2.4 Automatic Antenna Switch (option).....	2-13
3. INITIAL SETTING.....	3-1
3.1 Performance Check.....	3-1
3.2 Initializing Control Unit and Transceiver Unit.....	3-1
3.3 Manual 2182 kHz Tuning Preset.....	3-3
3.4 System Setup.....	3-5
3.5 Setting DIP Switches.....	3-9
3.6 Preamp Setting (For FAX-5).....	3-10
4. OPTION KIT.....	4-1
4.1 DSC Routine Frequency Board.....	4-1
4.2 Connecting of NBDP Terminal Unit OP05-96 (IB-581)/OP05-100 (IB-583).....	4-3
PACKING LISTS.....	A-1
OUTLINE DRAWINGS.....	D-1
INTERCONNECTION DIAGRAM.....	S-1

ECF

(Elemental Chlorine Free)

The paper used in this manual
is elemental chlorine free.

FURUNO ELECTRIC CO., LTD.

9-52 Ashihara-cho,
Nishinomiya, 662-8580, JAPAN

Telephone : +81-(0) 798-65-2111

Fax : +81-(0) 798-65-4200

• FURUNO Authorized Distributor/Dealer

All rights reserved.

Printed in Japan

Pub. No. IME-56360-J4

(HIMA) FS-1570/2570

A : AUG. 2002

J4 : SEP. 09, 2011



* 0 0 0 8 0 9 3 4 2 1 5 *



SAFETY INSTRUCTIONS



DANGER



Do not touch cable from the antenna coupler during transmission.

Electrical shock, serious injury or death can result if the cables are touched during transmission.

Do not touch this point.

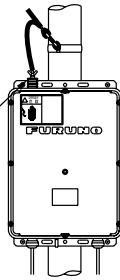

Do not touch the whip antenna or wire antenna.

Electrical shock, serious injury or death can result if the antenna is touched during transmission.



WARNING



Do not work inside the equipment unless totally familiar with electrical circuits.

Hazardous voltage which can shock exists inside the equipment.



Turn off the power at the mains switchboard before beginning the installation. Post a sign near the switch to indicate it should not be turned on while the equipment is being installed.

Fire, electrical shock or serious injury can result if the power is left on or is applied while the equipment is being installed.



CAUTION

Confirm that the power supply voltage is compatible with the voltage rating of the equipment.

Connection to the wrong power supply can cause fire or equipment damage to the equipment. The voltage rating appears on the label at the rear of the display unit.



Ground the equipment.

Ungrounded equipment can give off or receive electromagnetic interference or cause electrical shock.

Use copper strap with careful.

An edge of it may harm your hand.

Keep the following compass safe distances.

		Standard compass	Steering compass
Transceiver Unit	FS-1570T	1.20 m	0.70 m
	FS-2570T	2.20 m	1.40 m
FS-2571C		0.90 m	0.60 m
HS-2003		1.50 m	0.95 m
AT-1560-15 AT-1560-25		1.00 m	0.70 m
PP-510		1.00 m	0.80 m
IC-302/303		0.80 m	0.60 m
SEM-21Q		2.20 m	1.50 m
PR-850A		1.00 m	0.70 m
PR-300		0.90 m	0.70 m
IB-581		1.40 m	1.00 m
IB-583		0.70 m	0.40 m
AS-102		0.65 m	0.40 m

SYSTEM CONFIGURATIONS

Standard configuration is shown with solid line.

FS-1570

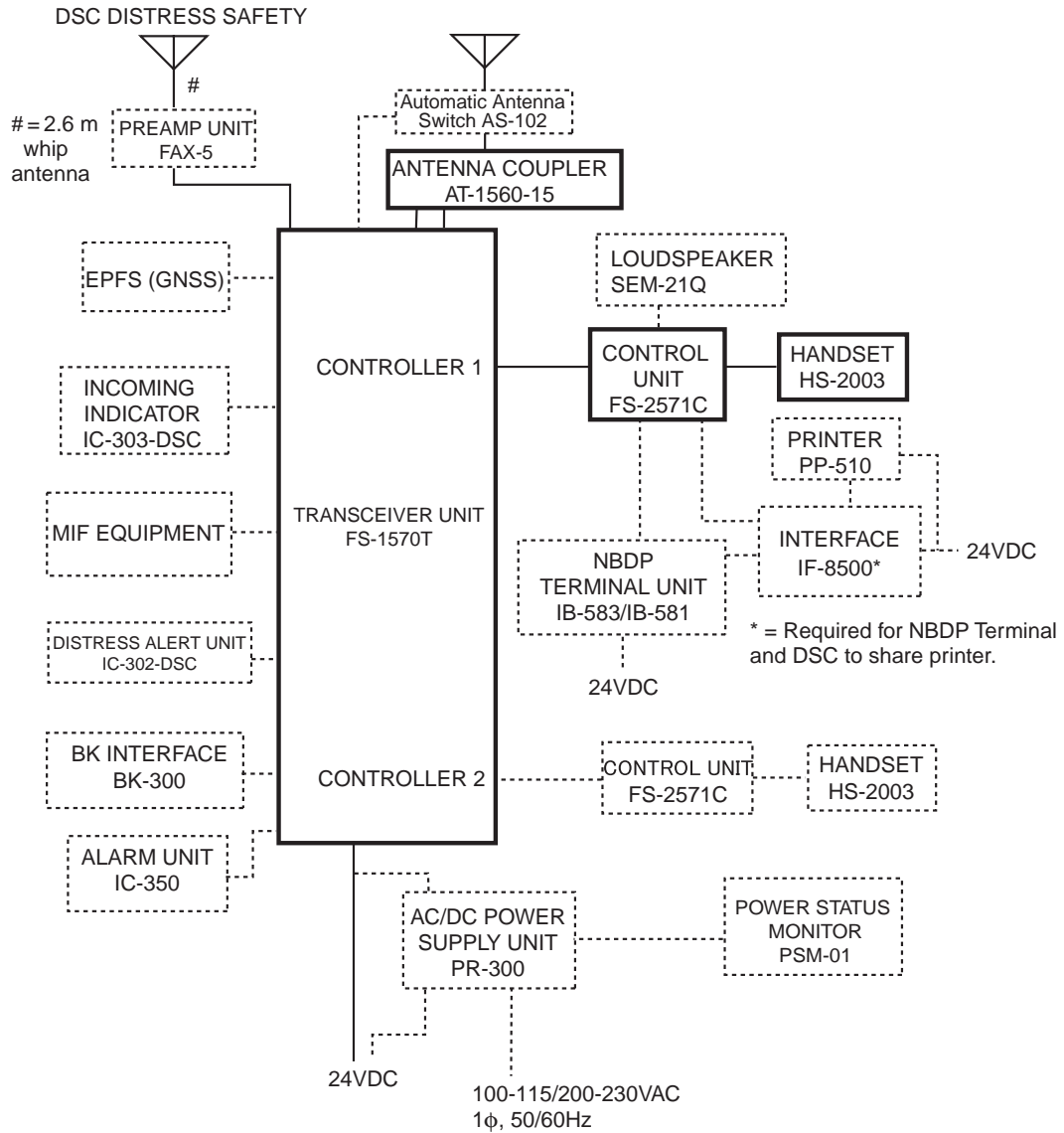

Unit	Category
Preamp Unit	Exposed to weather
Antenna Coupler	Exposed to weather
Other Units	Protected from weather

FS-2570

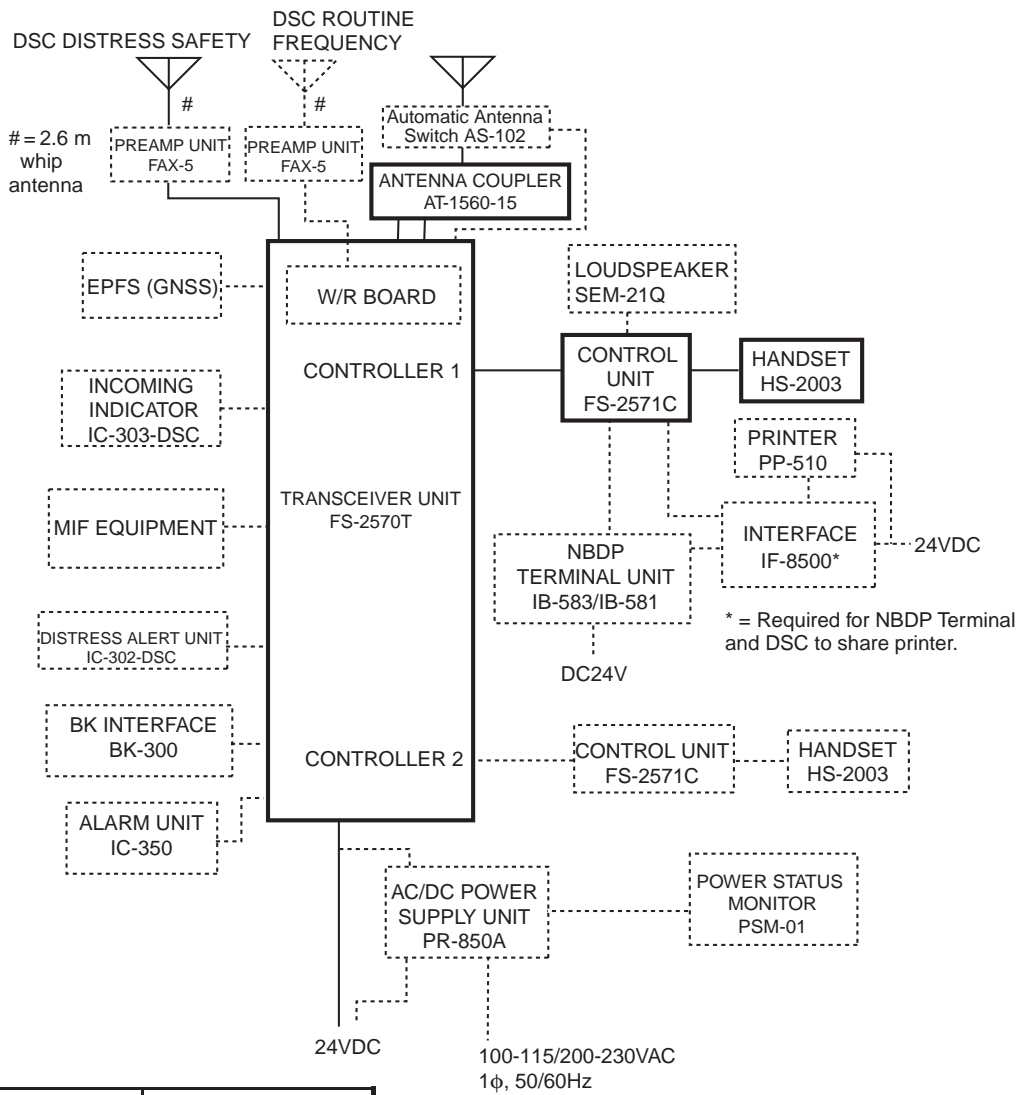

Unit	Category
Preamp Unit	Exposed to weather
Antenna Coupler	Exposed to weather
Other Units	Protected from weather

EQUIPMENT LISTS

Standard Supply

Name	Type	Code no.	Qty	Remarks		
Transceiver Unit	FS-1570T	-	1	For FS-1570 (150 W)		
	FS-2570T	-		For FS-2570 (250 W)		
Control Unit	FS-2571C	-	1			
Antenna Coupler	AT-1560-15-AAS	-	1	For FS-1570, Resin		
	AT-1560-15-SUS	-		For FS-1570, Stainless steel		
	AT-1560-25-AAS	-		For FS-2570, Resin		
	AT-1560-25-SUS	-		For FS-2570, stainless steel		
Accessories	FP05-05700	000-054-228	1	Handset, bracket, etc.		
Installation Materials	CP05-08810	000-056-951		17JE23150-02 (D8C), 10 m cable	Between control unit & Transceiver unit.	
	CP05-08820	000-056-952		17JE23150-02 (D8C), 20 m cable		
	CP05-08830	000-056-953		17JE23150-02 (D8C), 30 m cable		
	CP05-08840	000-056-954		17JE23150-02 (D8C), 40 m cable		
	CP05-08850	000-056-955		17JE23150-02 (D8C), 50 m cable		
	CP05-05700	000-055-238	1 set	For antenna coupler		
	CP05-08801	005-951-930	1 set	For control unit		
	CP05-08802	005-952-180	1 set	For transceiver unit		
	05S0949 L-10	000-130-484	1	10 m	For antenna coupler	
	05S0949 L-20	000-130-485		20 m		
	05S0949 L-30	000-130-486		30 m		
	05S0949 L-40	000-130-487		40 m		
	05S0949 L-50	000-130-488		50 m		
	05S0462 L-10	000-113-360	1	10 m		For antenna coupler
	05S0462 L-20	000-113-361		20 m		
	05S0462 L-30	000-113-362		30 m		
	05S0462 L-40	000-113-363		40 m		
	05S0462 L-50	000-113-364		50 m		
	05S0793	000-125-984	1	10 m	For antenna coupler (w/armor)	
	05S0793	000-125-986		20 m		
05S0793	000-125-987	30 m				
05S0793	000-125-988	40 m				
05S0793	000-125-989	50 m				
RG-10/U-Y	000-125-999	1	10 m	For antenna coupler (w/armor)		
RG-10/U-Y	000-563-044		20 m			
RG-10/U-Y	000-563-048		30 m			
RG-10/U-Y	000-126-000		40 m			
RG-10/U-Y	000-126-001		50 m			

Optional Equipment

Name	Type	Code no.	Qty	Remarks
AC-DC Power Supply Unit	PR-300	-	1	For FS-1570 (150 W)
	PR-850A	-	1	For FS-2570 (250 W)
Printer	PP-510	-	1 set	w/installation materials (CP16-01200), accessories (FP16-00100)
Printer Interface Kit	IF-8500	000-053-895	1	
Distress Alert Unit	IC-302-DSC	-	1 set	w/Installation materials
Incoming Indicator	IC-303-DSC	-	1 set	w/Installation materials
Whip Antenna	04S4176	000-153-122	1	2.6 meter
	WH-027-10M	001-139-400-10		10 m
Preamp Unit	FAX-5	000-075-016	1 set	w/cable, 15 m
		000-075-049		w/cable, 1 m
External Loudspeaker	SEM-21Q	000-144-917	1	
Control Unit	FS-2571C	-	1 set	
NBBDP Terminal Unit Set	OP05-96	000-056-949	1 set	Terminal Unit IB-581, DSP print, Accessories
	IB-583	000-043-435	1 set	Terminal Unit IB-583 (w/accessories, spare parts)
Handset	HS-2003	-	1 set	w/Bracket
Cable assy.	MJ-A10SPF/SRMD-500	000-147-336	1	0.5m, For handset
Flush mount Kit	OP05-98	005-951-830	1	For control unit
W/R2 set	OP05-99	005-951-840	1 set	For FS-2570, P.C.B.
Cable assy.	17JE23150-02 (D8C) 5 m	000-146-015	1	5 m cable
	17JE23150-02 (D8C) 10 m	000-146-016		10 m cable
	17JE23150-02 (D8C) 20 m	000-146-017		20 m cable
	17JE23150-02 (D8C) 30 m	000-146-018		30 m cable
	17JE23150-02 (D8C) 40 m	000-146-019		40 m cable
	17JE23150-02 (D8C) 50 m	000-146-020		50 m cable
BK Interface	BK-300	-	1 set	
Antenna Materials	CP05-09010	005-954-180	1 set	
Cable	05S9509-L500	000-168-955-10	1	For handset extension
Automatic Antenna Switch	AS-102	-	1	
Manual Tilting Mechanism	WH-027-KD	001-139-410-10	1	For whip antenna WH-027-10M

This page is intentionally left blank.

1. MOUNTING

1.1 Control Unit

1.1.1 Mounting methods

The control unit can be mounted one of four ways;

- In the hanger (overhead, bulkhead or tabletop)
- Flush mounting.

1.1.2 Mounting considerations

- Make sure the location is strong enough to support the unit under the conditions of continued vibration and shock normally encountered on the boat.
- Locate the unit where it is easily accessible and does not interfere with personnel or operation of other equipment; for example, ship's wheel.

1.1.3 Hanger mounting

1. Fix the hanger with tapping screws (supplied).
2. Set the control unit to the hanger and fix it with the washers and knobs.

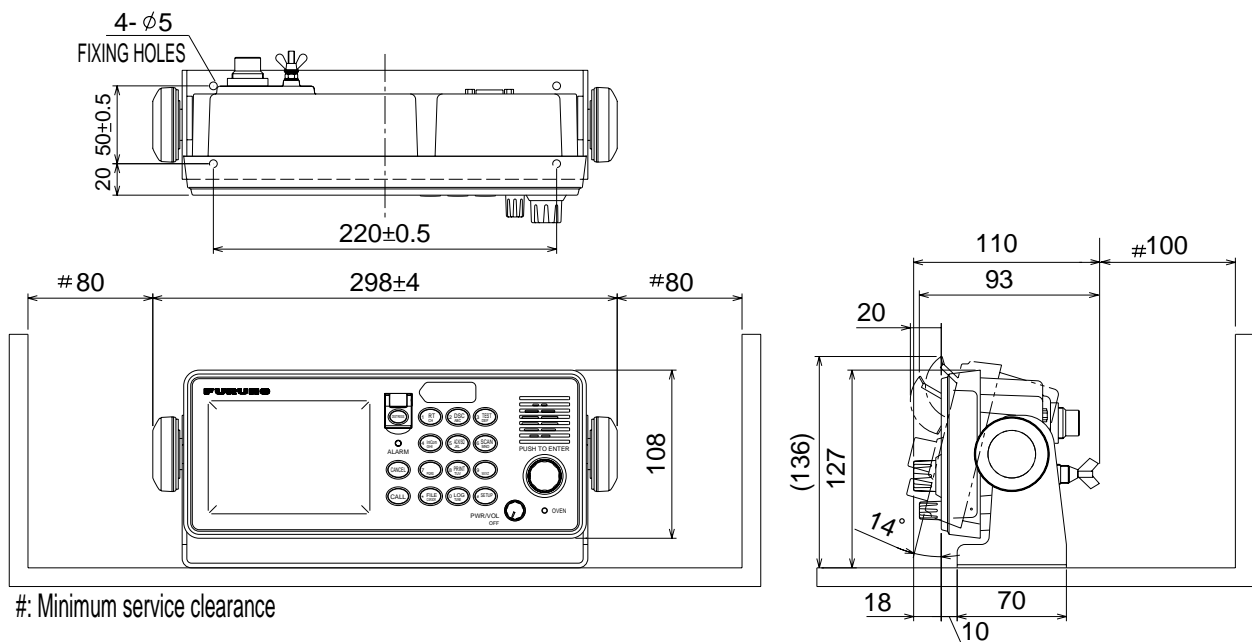

Mounting the control unit

1.1.4 Flush Mounting

Use the optional flush mount kit.

Name: Flush mount kit

Type: OP05-98

Code No.: 005-951-830

Name	Type	Code No.	Qty	Remarks
Mounting metal	05-089-1171	100-299-020	2	
Wing bolt	M4x30	000-804-799	4	
Wing nut	M4	000-863-306	4	
Hex. bolt	M6x12	000-162-897-10	2	
Spring washer	M6	000-158-855-10	2	

1. Make a cutout of 251 mm (W) x 100 mm (H).
2. Insert the control unit to the cutout.
3. Attach two mounting metal (supplied with kit) to the control unit with hex bolts (M6 x 12, supplied with kit) and spring washer (supplied with kit) from the rear side.
4. Screw four wing bolts (supplied with kit) to wing nuts (supplied).
5. Fasten the control unit to the mounting location with four wing bolts and nuts assembled at step 3.

Flush mounting, side view

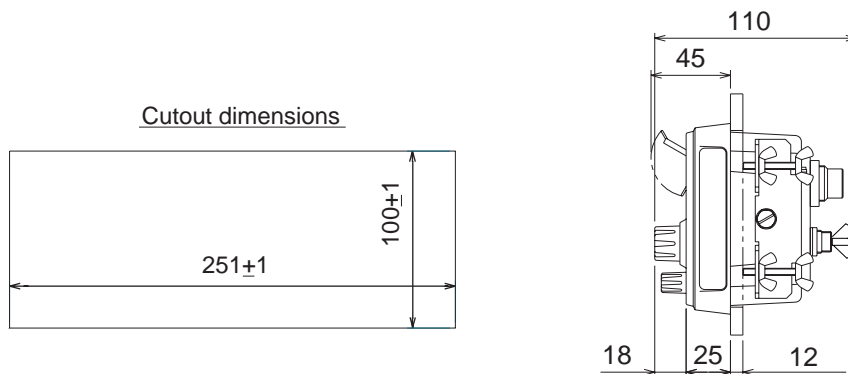

Flush mounting

1.2 Antenna Coupler

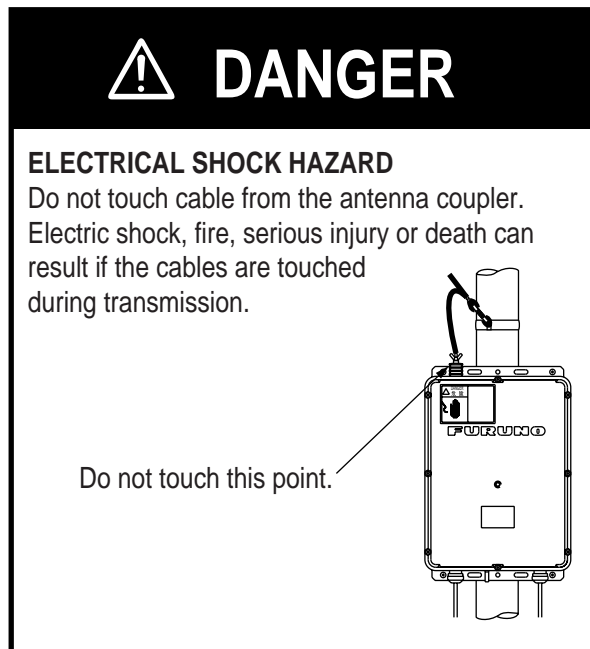

1.2.1 Introduction

The antenna coupler is installed between the antenna and the transceiver, and tunes the antenna to the transmitter.

The importance of a good ground system cannot be overemphasized. Without a good ground, this unit will not work properly – if at all.

Note: The T/R antenna is automatically connected to ground when the power is turned off.

1.2.2 Ground System

A good antenna can work well only when an efficient RF ground is provided. Without a good ground system, the full potential of this radio cannot be realized.

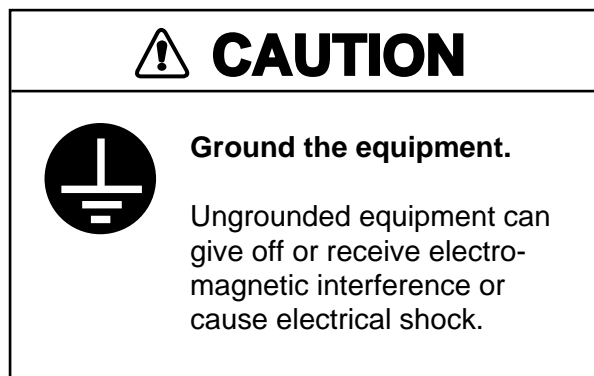

Grounding

Run a copper strap (supplied) between the ground terminal of the antenna coupler and the ship's superstructure.

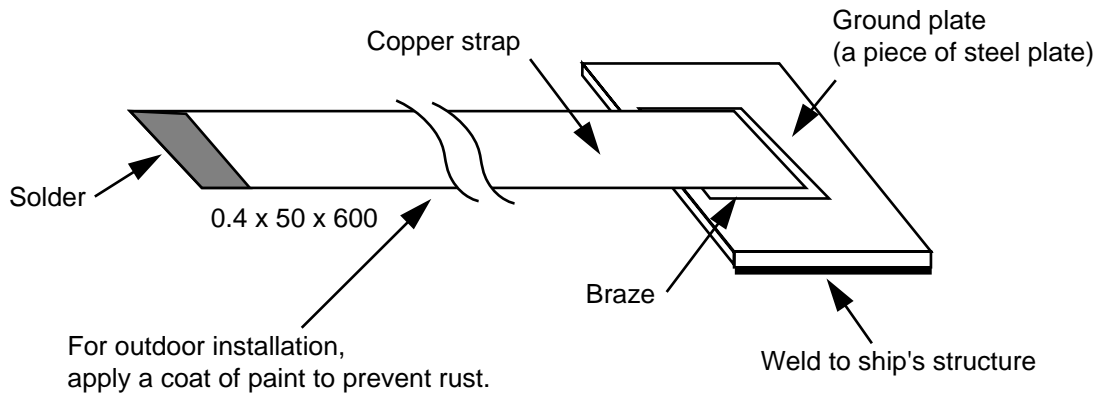

Ground for metallic hull

1.2.3 Mounting considerations

The water-jetsproof construction of the antenna coupler permits installation either indoors or outdoors. When selecting a location, keep in mind the following points.

Outdoor installation

- Select a location not exposed to salt water spray. Salt water on the antenna insulator may cause unstable operation of the coupler and in the worst case prevent transmission.
- All wires from the coupler to the antenna radiate radio energy. They should be routed away from any grounded conductors such as mast shrouds, or fittings.
- For optimum radio energy, locate the coupler as near to the ground as possible.
- The length of the vertical portion of the antenna should be as long as possible.
- Leave enough space around the sides of the unit to permit maintenance and checking.
- Total antenna length should be 7 to 30 meters.

Indoor installation

- Locate the unit away from GPS and radio equipment to avoid mutual interference.
- The lead-in wire should be as near to the unit as possible.
- Select a place where the unit can be easily maintained, but where it will not interfere with crew or passengers.
- Overhead mounting is available for indoor installation.

1.2.4 Anti-moisture measure (vent tube)

The vent tube (attached) prevents moisture from being drawn into the enclosure during atmospheric pressure changes and allows trapped humid air to escape. Install it according to coupler installation method, before mounting coupler.

Vertical or horizontal installation

Two vent holes are provided on the coupler, one at the bottom and one on the rear. The vent tube is set to vent hole B at the factory. This location is for vertical installation of the coupler. For horizontal installation, remove the vent tube from vent hole B and set it to vent hole A. Cover vent hold B with seal (supplied), from inside the coupler.

1.2.5 Mounting

Fix the antenna coupler to a bulkhead of the bridge, mast, handrail, etc. For mounting on the mast, select a location within the total length of the antenna, and weld suitable mounting fixtures (local supply) to the mast and bolt the coupler there.

For indoor installation, select a location where the distance between the lead-in insulator and the coupler is as short as possible.

Example for outdoor installation

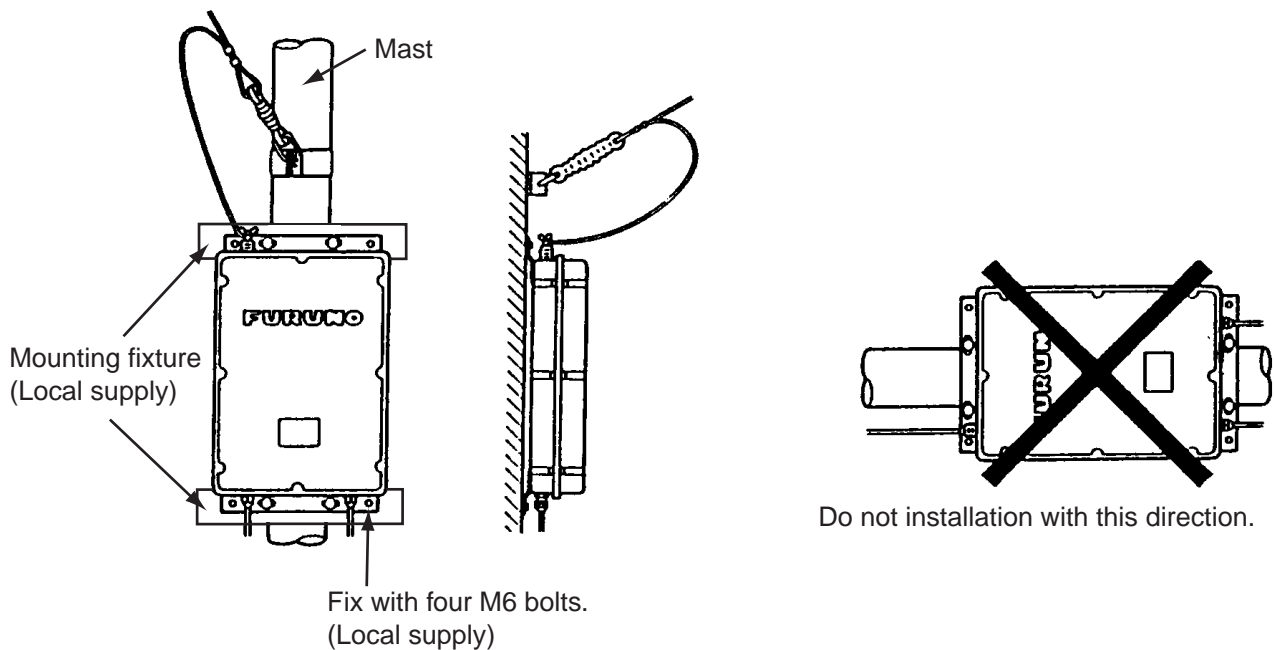

Example for antenna coupler mounting

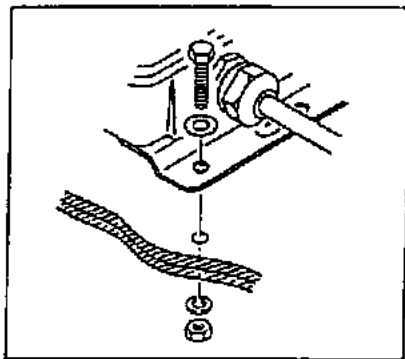
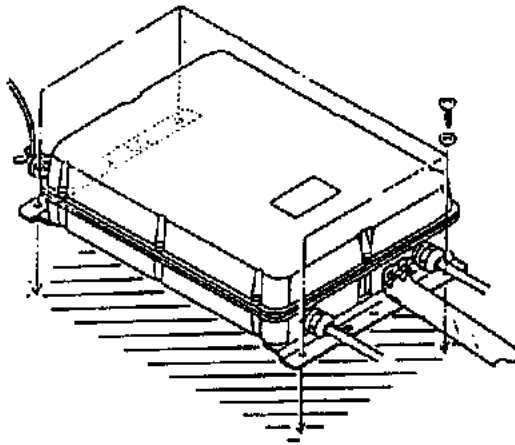

For thin bulkhead, use nuts, bolts and washers instead of tapping screws.

Example for indoor installation

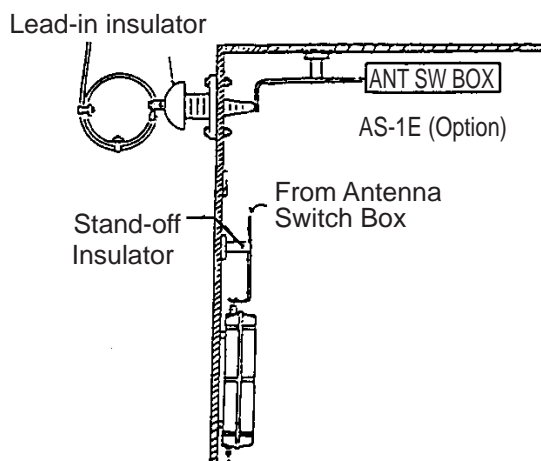

Mounting the antenna coupler

1.3 Transceiver Unit

- Bulkhead mounting only
- Select a location which provides adequate ventilation.
- The location must be clean and dry.
- The mounting location must be able to support the weight of the unit (FS-1570: 11.0 kg, FS-2570: 14.0 kg) under the continued conditions of vibration normally encountered aboard the vessel. If necessary, reinforce the mounting location.
- Secure the maintenance space shown in the outline drawing at the back of this manual, for ease of maintenance and service.

Transceiver unit

Ground the transceiver unit with the cable assy (05S0479, supplied), to prevent interference.

Fasten the transceiver unit to the mounting location with six tapping screws in the order shown below. (Asterisk-marked holes are not used.) For details, refer to outline drawings at the back of this manual.

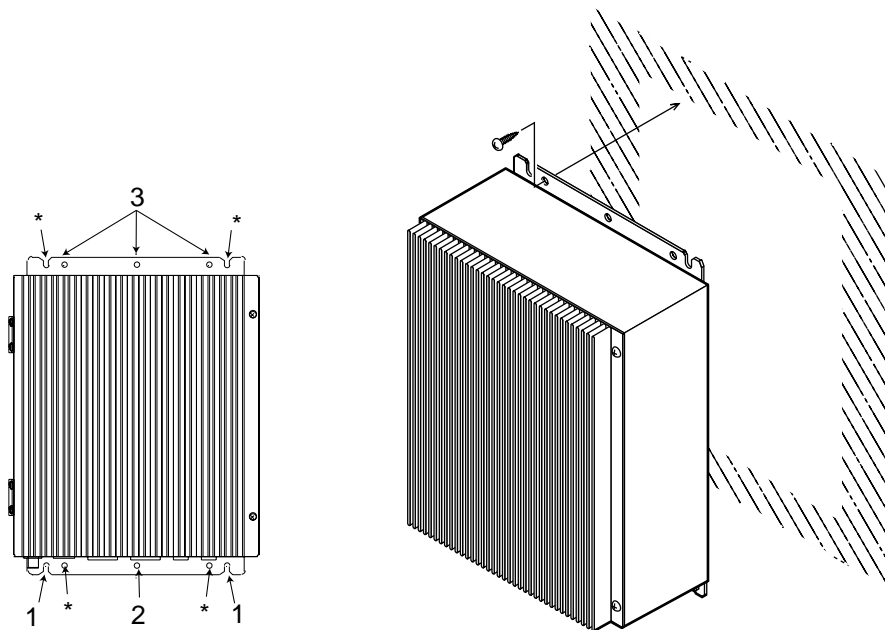

Transceiver unit (ex. FS-1570T)

1.4 Handset (w/bracket)

Unfasten six screws to remove the bracket cover, and fasten the bracket to the mounting location with two tapping screws 4 x 16 (supplied) on the desktop or bulkhead.

Note: The magnet inside the bracket may pull the screwdriver when mounting the hanger.

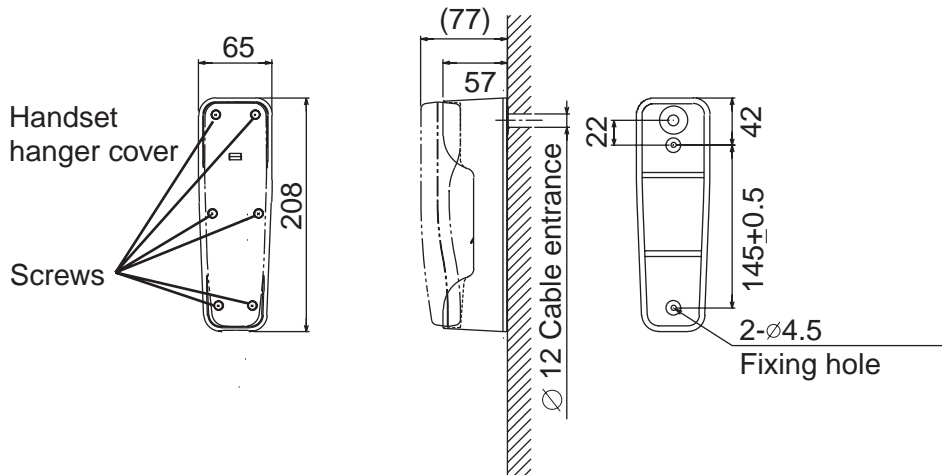

Handset (w/bracket)

1.5 Antenna

The antenna plays the most important role in radio communication. If it cannot receive or transmit due to improper installation, even the most sophisticated transceiver will be useless.

1.5.1 Types of antennas

The most commonly used antenna is an 8 m to 10 m whip antenna or a 10 m to 18 m long wire antenna. When using an 8 m whip antenna, secure with a 2 m lead-in wire as show in the illustration below:

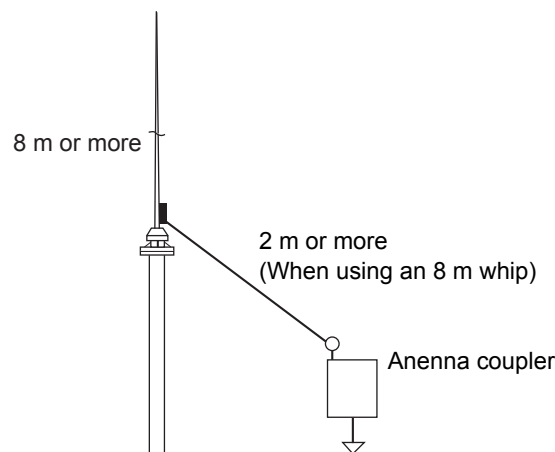

How to affix the whip antenna

The rated capacity of the MF band antenna must be 100 pF or more. This is suitable for antennas with a length of 10 m or more. If using an antenna with a length of less than 10 m, it is possible that the distance range will be insufficient. In addition, this may cause a burnout due to high voltage and frequency. A long wire antenna in general provides better performance than a whip antenna, provided the vertical part is long enough.

After setting up the equipment, be sure to confirm that the frequency matches the antenna length. If the frequency does not match, adjust the length of the antenna.

Transmitting antenna

- Total antenna length is 10 to 18 meters.
- The length of the vertical portion should be longer than eight meters, and the slant angle of that part should be within 10 degrees.
- Separate the transmitting antennas as far as possible from stays, metallic objects, direction finder antenna and INMARSAT radome antenna.
- Locate the insulator away from funnels, etc.
- If the antenna coupler is installed out of wheelhouse, use a lead-in insulator (FURUNO type: YA-256) to make the connection. If necessary, use a high quality antenna switch and stand-off insulator.
- If the antenna is connected directly to the coupler, use a strain insulator to prevent insulator fatigue.

Receiving antenna

A receiving antenna is required for duplex communication. Furuno can supply two types of receiving antennas: FAW-6RP2 (six meter whip, w/standard, mounting bracket), or FAW-6D3-110682-00 (six meter ship, w/universal mount).

The receiving antenna should be separated at least five meters from the transmitting antenna (as far as possible). Install a receiving antenna junction box at the base of the antenna.

1.6 Mounting of Optional Equipment

1.6.1 AC-DC power supply unit

Mounting considerations

When selecting a mounting location, keep in mind the following points.

- Select a location which provides adequate ventilation.
- The location should be clean and dry.
- The mounting location must be able to support the weight of the unit (PR-300:14.5 kg, PR-850A: 35 kg) under the continued conditions of vibration normally encountered aboard the vessel.
- A magnetic compass will be affected if the power supply unit is placed too close to it. Observe the following compass safe distances to prevent disturbance to the magnetic compass shown on page ii.

Mounting

Refer to the outline drawings at the back of this manual.

1.6.2 Preamp unit FAX-5

The body of preamp unit can be mounted two ways:

1. The bottom of the preamp unit is designed to accept a threaded extension mast of 1 inch diameter. The pitch of the thread should be 14 threads per inch. To prevent undue flexing of the mast in heavy winds, the mast should not be longer than 5 feet (1.5 m).
2. The side of the preamp unit has a molded channel so that it may be mounted directly to a stub mast with two stainless steel hose clamps. Hose clamps must be arranged locally.

Screw the 2.6 m whip antenna (option) tightly onto the preamp unit and waterproof the junction and other exposed metallic parts with sealing compound (silicone rubber, putty, etc.)

Note that a wire antenna of 2 to 3 meters length may be used instead of the whip antenna.

Note: The preamp unit requires 12 VDC power. See paragraph 3.5 for how to provide power to the preamp unit.

50 Thread
(14 threads/inch)

1" Pipe

Spring Washer 2.6m Whip Antenna

Hose Clamp Mast

Earth

Coupling Nut

Antenna Wire

Wire Antenna Fixture

Preamp Unit

Mounting of preamp unit

1.6.3 Printer PP-510

Install the unit with the two mounting fixtures (supplied). Refer to the outline drawing at the end of this manual. Connect the interconnection cable between the printer and the transceiver unit. For how to load paper and set ribbon cassette, refer to the Operator's Manual of the printer.

Mounting

1. Select a flat surface. (Compass safe distance: Standard, 1.0 meters, Steering, 0.8 meters).
2. Fix the printer to the mounting location with two mounting fixtures.

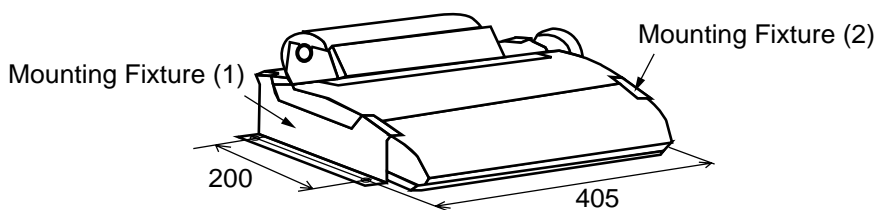

Dimensions of printer PP-510

1.6.4 Distress alert unit IC-302-DSC/Incoming indicator IC-303-DSC

Select the mounting location where the button on the unit can be operated easily in an emergency. See the back of the manual for mounting dimensions and recommended clearance space. (Compass safe distance: Standard, 0.8 meters, Steering, 0.6 meters)

1. Unfasten four screws to remove the cover.

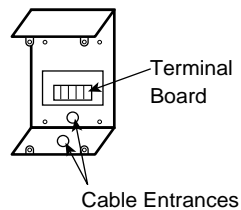

IC-302-DSC/IC-303-DSC

2. Fasten the unit with four tapping screws.
3. Pass the cable through appropriate entrance to connect to the terminal board. There are two cable entrances, one at the bottom and one on the back. Select one.
4. Attach the cover with four screws.
5. Clamp the cable outside of the unit with cable clamp (local supply).

1.6.5 External loudspeaker

The external loudspeaker can be installed on a tabletop, the overhead or bulkhead. Fasten the loudspeaker to the mounting location with tapping screws, or nuts, bolts and washers. For mounting dimensions, see the outline drawing at the back of this manual. The external loudspeaker should be mounted within 2.8 m from the control unit because of the cable length.

1.6.6 Printer interface

Referring to the outline drawing at the end of this manual, fix the printer interface with tapping screws (local supply) to tabletop or bulkhead.

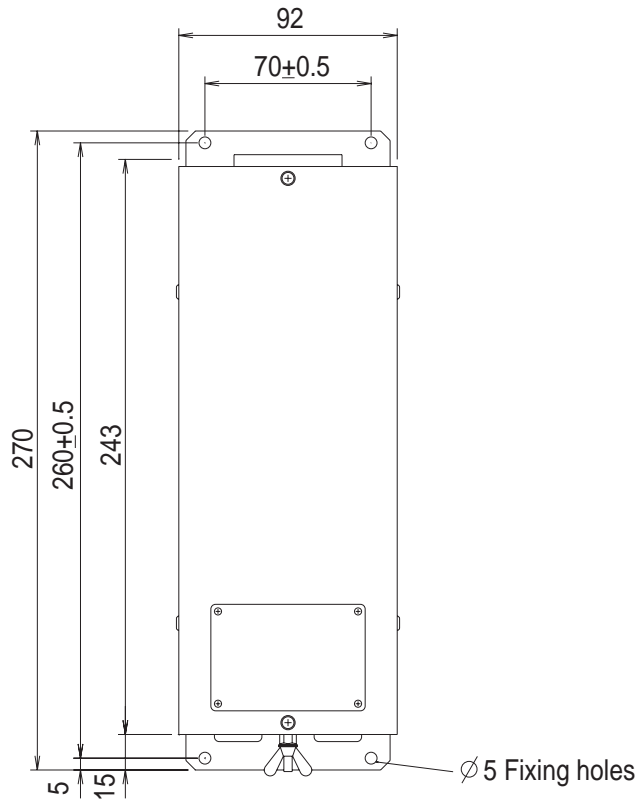

1.6.7 Automatic Antenna Switch

Install the automatic antenna switch between the SSB antenna and the antenna coupler. This unit allows you to connect the antenna to ground remotely when there is a possibility of lightning or the antenna must be grounded to comply with local regulations when returning to a harbor. Mount the unit on the bulkhead by using four self-tapping screws (5x20, supplied).

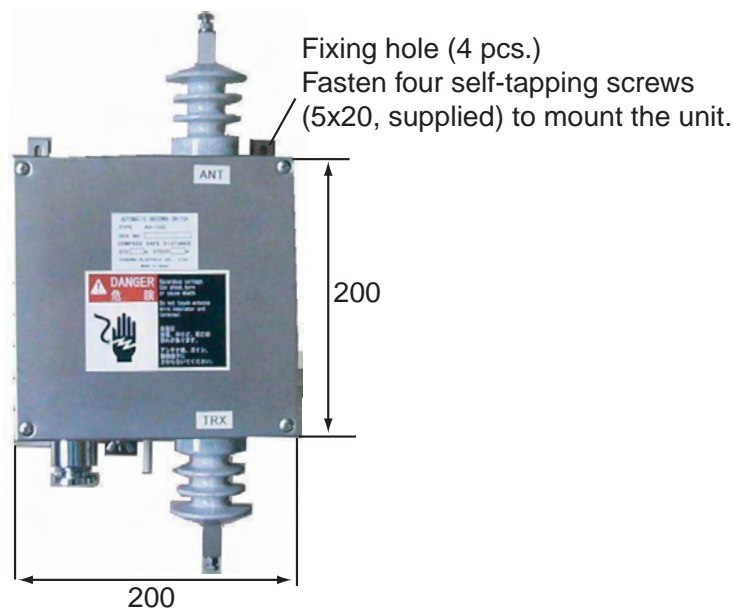

2. WIRING

2.1 Wiring

2.1.1 Standard wiring

For further details, refer to the interconnection diagram at the end of this manual.

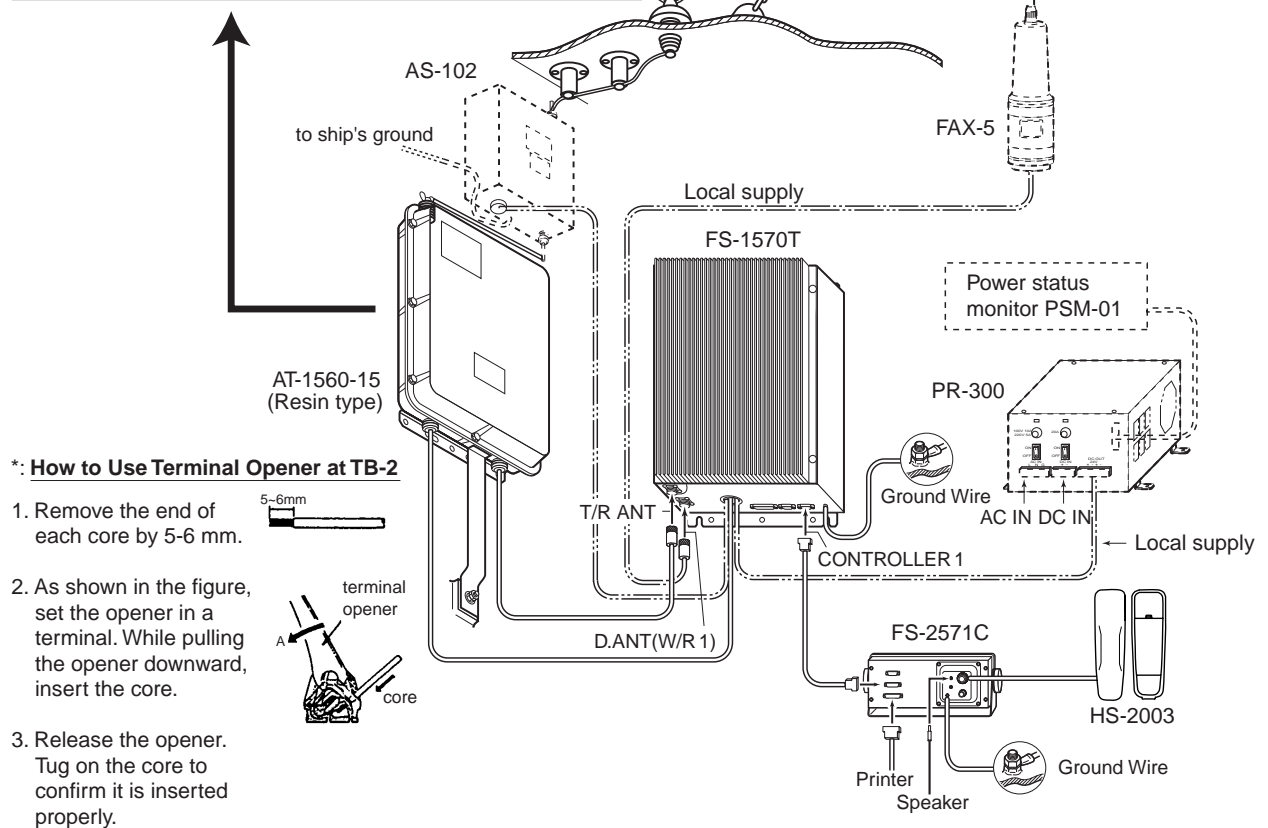
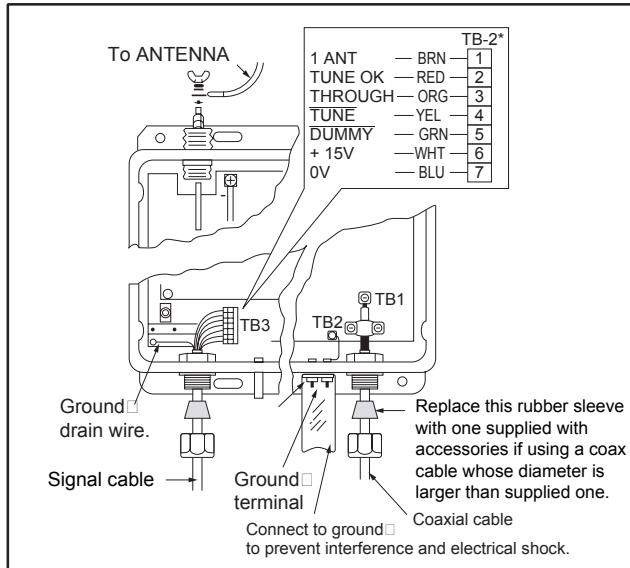

Wiring (FS-1570)

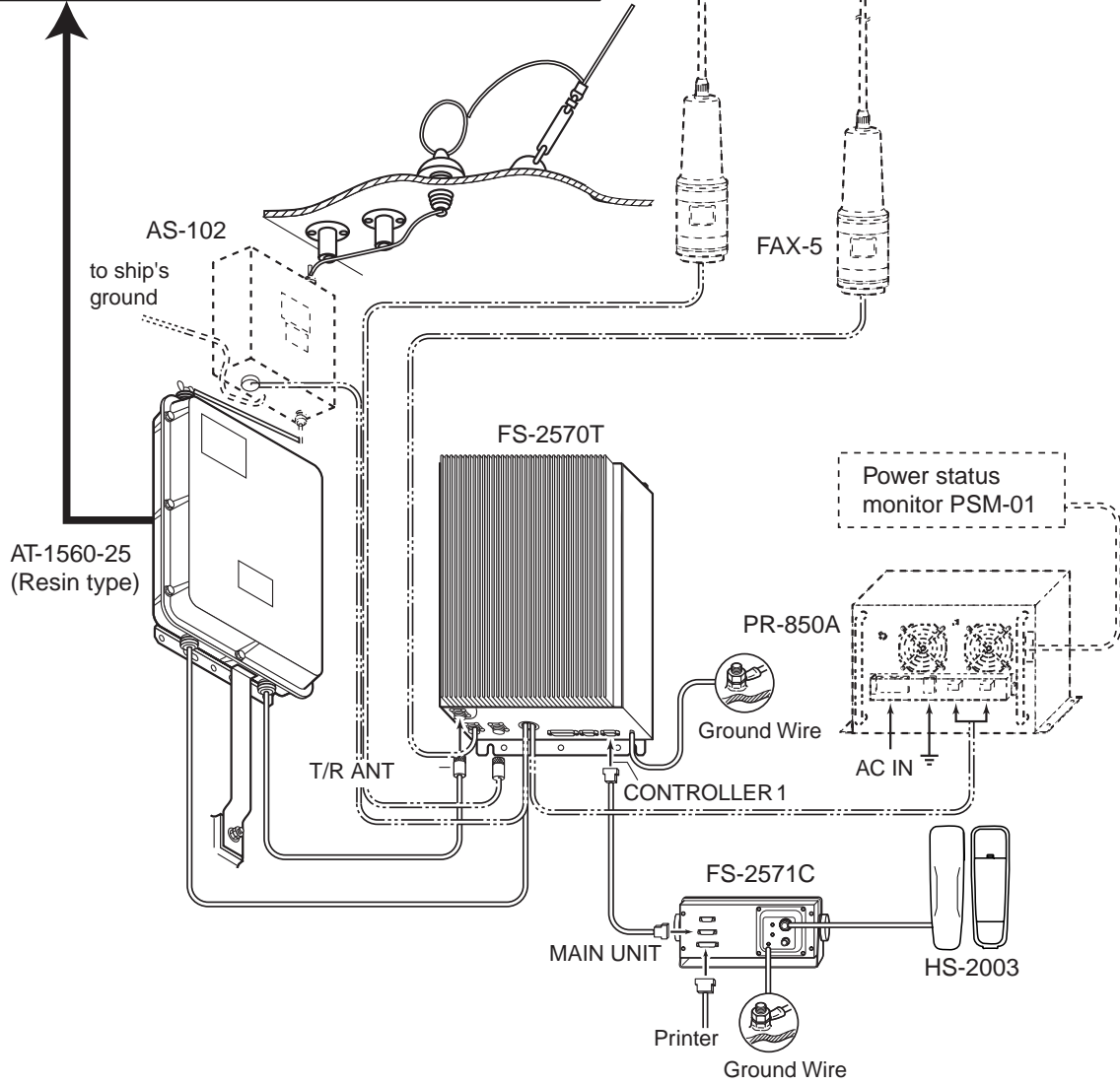
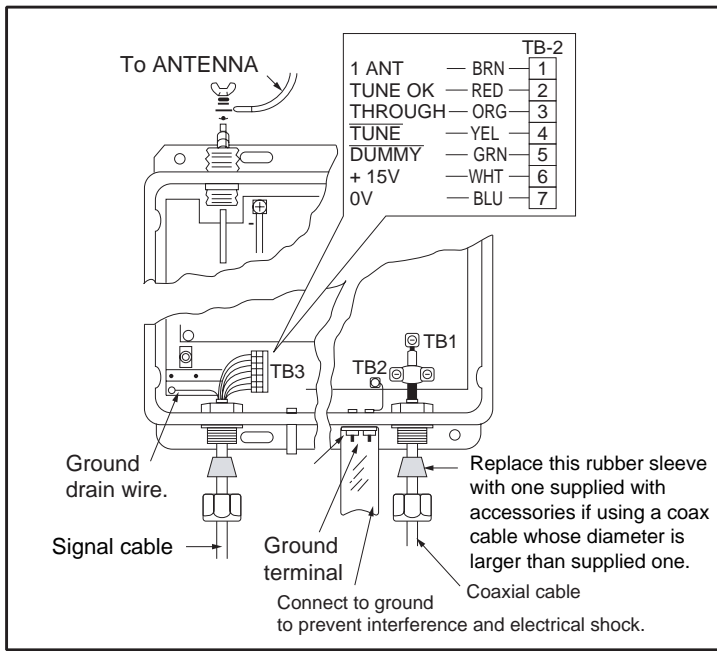

Wiring (FS-2570)

2.1.2 Connection on the transceiver unit

Power cable

Cut the rubber bush to the form of cross with knife.

Pass the power cable (supplied) through the hole at the bottom of the transducer unit, and fasten it to the TB1 and 2. Fasten it to the fixing plate at cable entrance with a cable tie (local supply.) When connecting to the optional AC-DC power supply unit PR-300 (FS-1570) or 850A (FS-2570), supply AC power and DC power to the PR-300/850A. See paragraph "2.3 Connection of AC-DC Power Supply Unit" for detail.

Antenna coupler cable

Cut the rubber bush to the form of cross with knife.

Cut the connector of the signal cable (05S0949 or 05S0793) off, pass the cable to the rubber bush, and then connect the cable to TB5 on the T-IF Board (05P0731) (See Note 1.). Wrap vinyl tape or attach an insulating tube to the shield wire to prevent the shorting to the board. Fasten the signal cable to the fixing plate with a cable tie (local supply.)

Attach the M-type connector of the coaxial cable (05S0462 or RG-10/U-Y, from the antenna coupler) to T/R ANT port. Note that when running the coaxial cable, attach it with slack for opening/closing the lid.

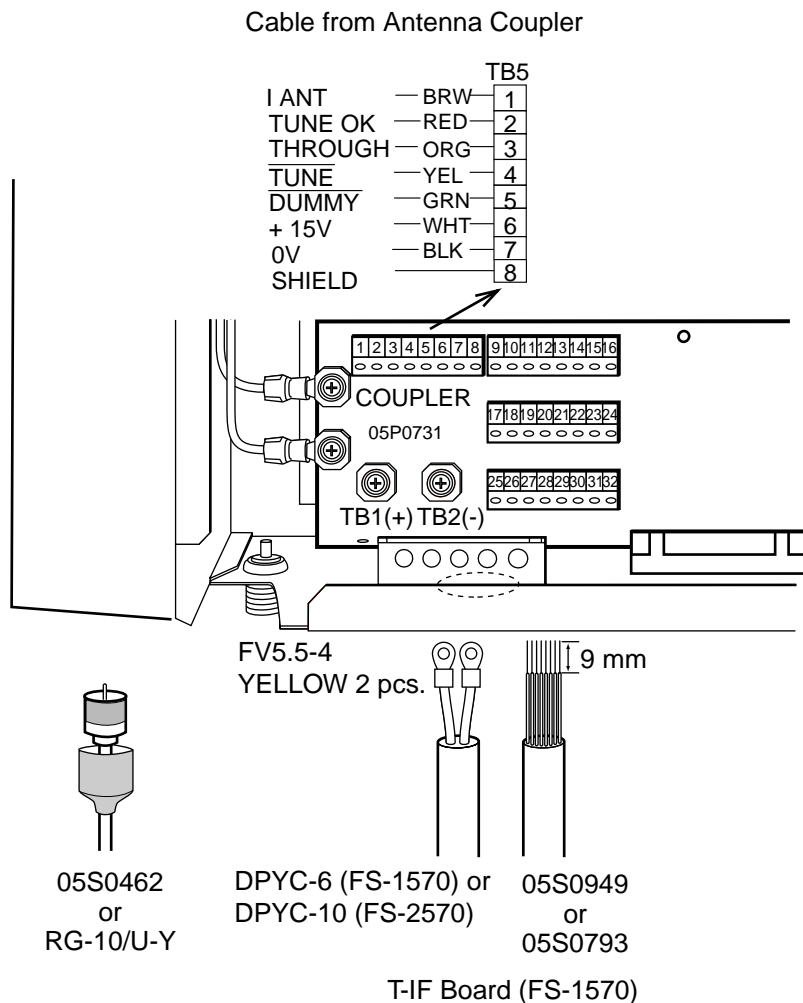

Connection of transceiver unit

Note1: How to connect cable to the terminal board.

1. Press this downward by finger or screw driver.

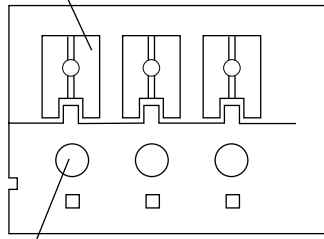

2. Insert a core of cable.
3. Release the finger or screw driver.

Control unit

Connect the transceiver unit and the control unit by the supplied cable with D-sub 15 pin connector for both ends. The control unit connected to the CONTROLLER 1 port has priority.

Connect the handset HS-2003 to the HANDSET 1 port at the rear of the control unit. For other handset or microphone, connect to the HANDSET2/MIC port. Note that these two ports can not be used at the same time.

Antennas

The antenna for DSC distress (mandatory) and DSC routine frequency (option for FS-2570 only) are connected to the transceiver unit with a 50 ohm coaxial cable, type RG-8/U or equivalent. Be sure to leave some slack in the cable for future service and maintenance. Lay the coaxial cable and attach an M-type plug to the cable as follows.

1. Remove the sheath by 30 mm.
2. Bare 23 mm of the center conductor. Trim braided shield by 5 mm and tin.
3. Slide coupling ring onto cable.
4. Screw the plug assembly on the cable.
5. Solder plug assembly to braided shield through solder holes. Solder contact sleeve to conductor.
6. Screw coupling ring into plug assembly.
7. Screw the plug into the D. ANT (W/R 1) port for DSC distress and ANT (W/R 2 port) for DSC routine frequency (option) at the bottom of the transceiver unit.

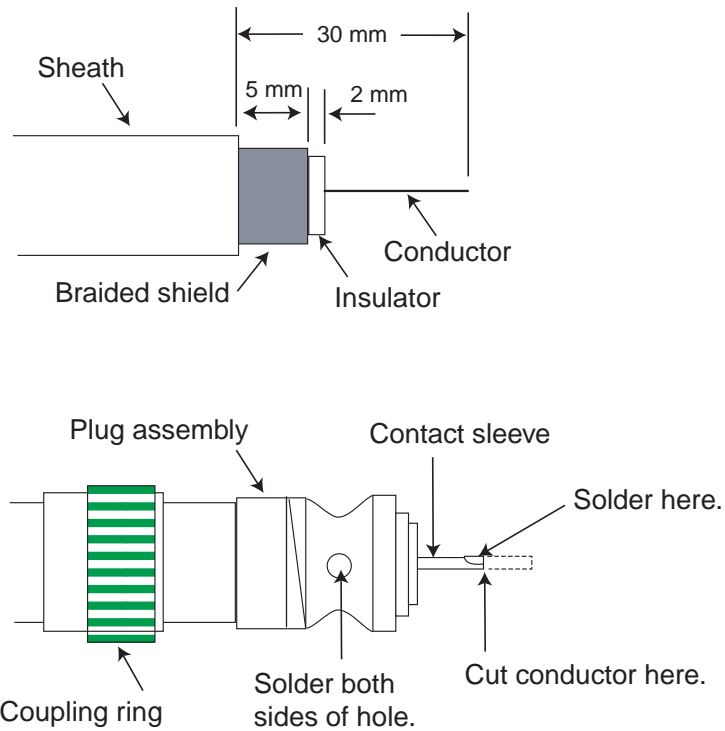

Fabrication of 50 ohm coaxial cable

2.2 External Equipment

Cables for the external equipment are connected to the terminal board in the transceiver unit. For location, see the interconnection diagram at the back of this manual.

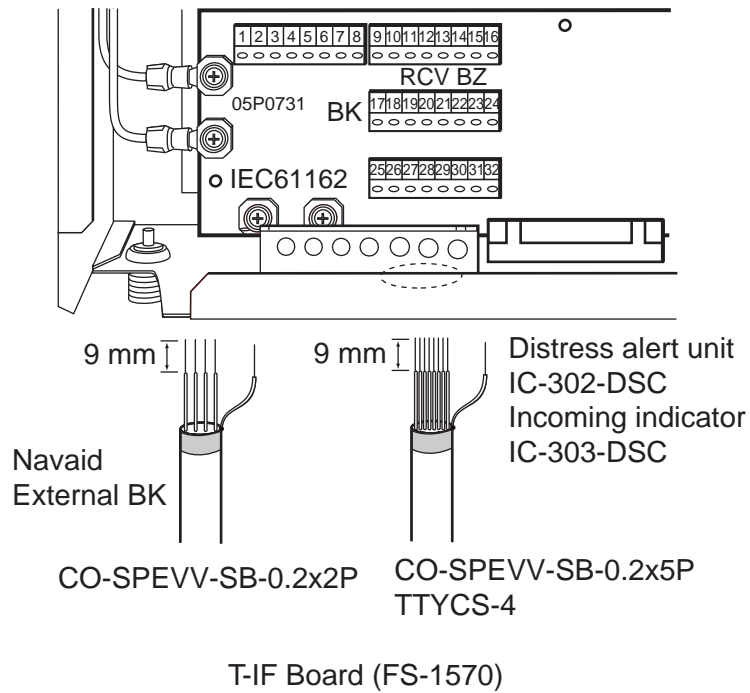

Connection of external equipment

IEC61162-1 (NMEA) equipment

Connects a navigator to the terminal box in the transceiver unit. The FS-1570/2570 can receive the following sentences in IEC-61162-1 (ed.2nd) format. Use the interconnection cable type CO-SPEVV-SB-C 0.2x2P (option).

- GLL: Latitude and longitude
- RMC: Generic navigation information
- GGA: GPS position, UTC
- ZDA: UTC, day, month, and year
- RMA: Minimum Loran-C data

Priority: GGA>RMC>GLL Priority is kept for one minute.

Distress alert IC-302

Use CO-SPEVV-SB-0.2x5P cable (option). For the fabrication, see the figure in below.

Indicator IC-303

Use CO-SPEVV-SB-C 0.2x5P cable (option) and fabricate it as below.

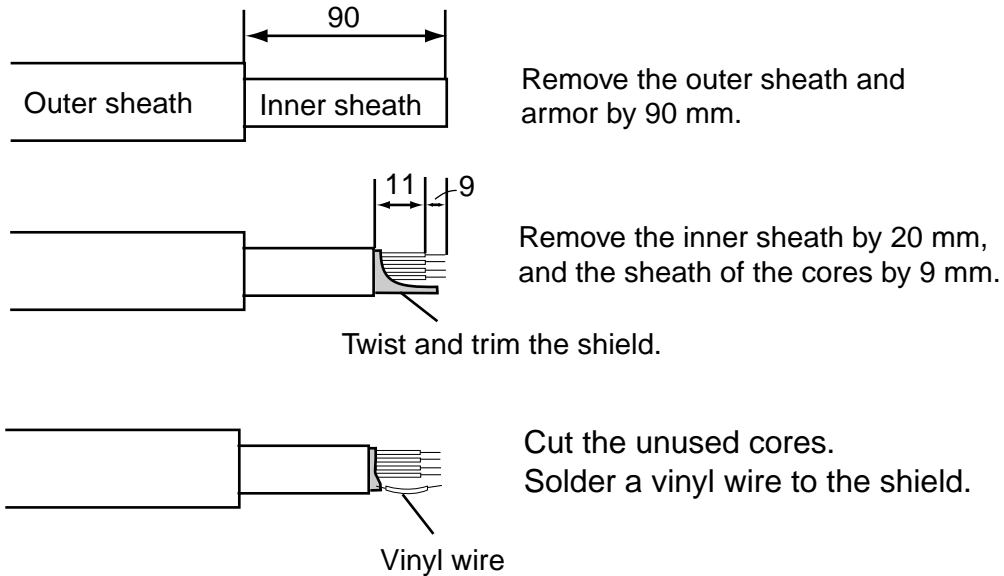

Fabrication of CO-SPEVV-SB-C for connect to the transceiver unit

External BK

Terminal No.	Signal name	Function	Object
17	BK (+)	Output voltage: 24 VDC	Power of relay BK for other radiotelephone
18	BK GND	GND	0 V
19	Tx_KEY	Go to GND on transmitting.	BK control for other radiotelephone
20	Rx_MUTE	Receiver unit goes to off when this line is GND.	BK control from other transceiver unit
21	SHIELD		

Note: When GND line from other radiotelephone is connected to the chassis, float the ground.

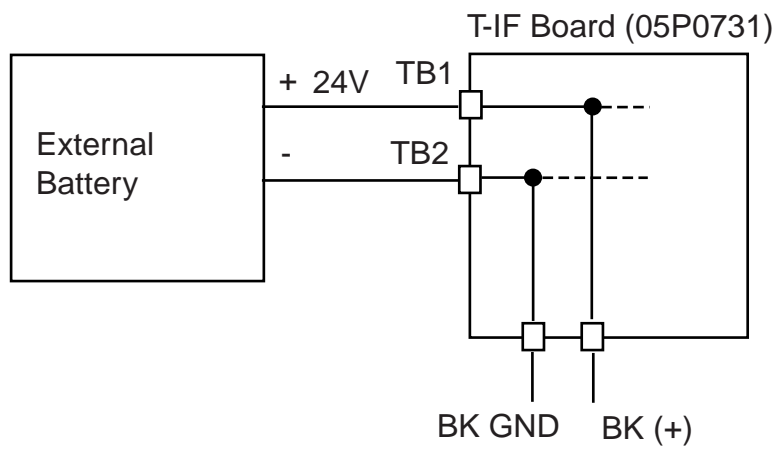

Power of BK

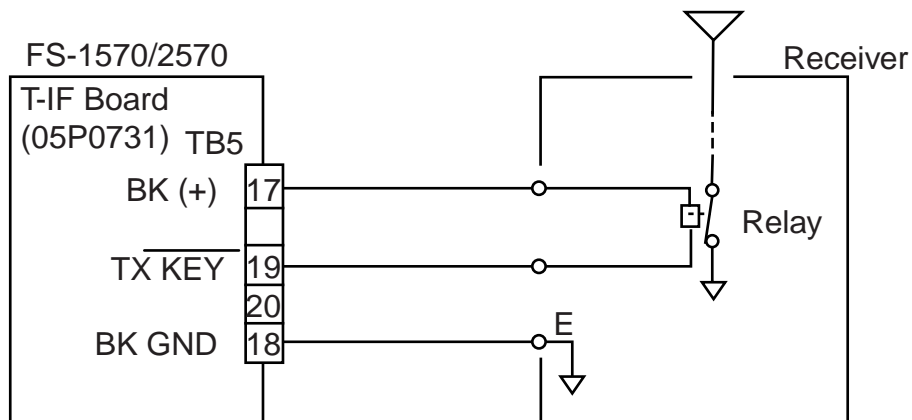

Example of connection with receiver

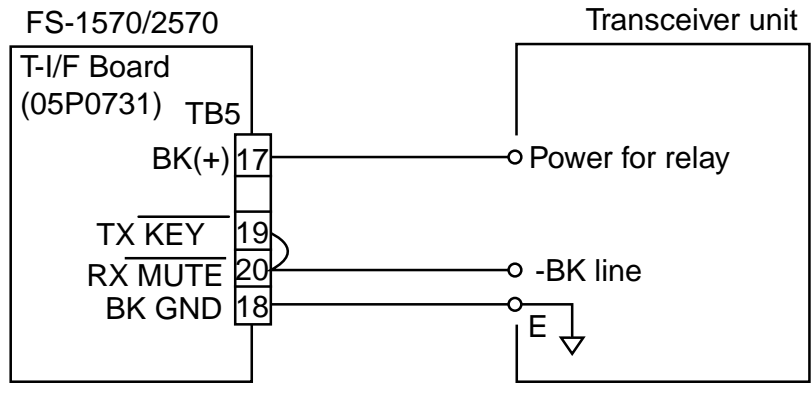

Example of connection with Tx/Rx unit

MIF unit (future addition)

Use 17JE-13250-02 connector (supplied as installation materials) to connect MIF unit to REMOTE port on transceiver unit.

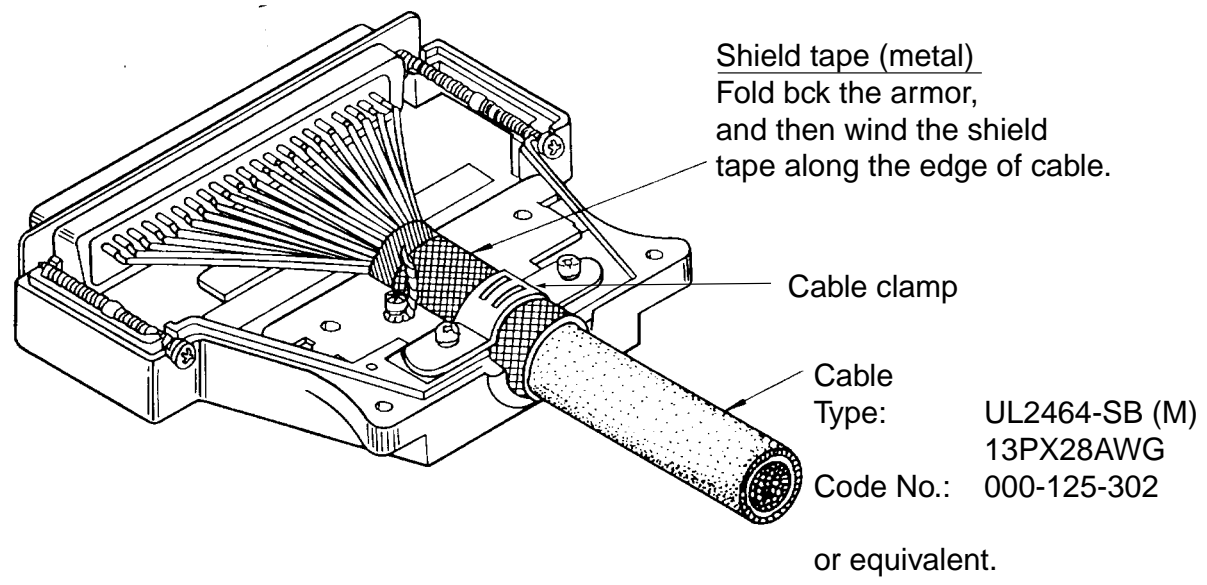

Fabrication of cable for MIF unit

Printer interface

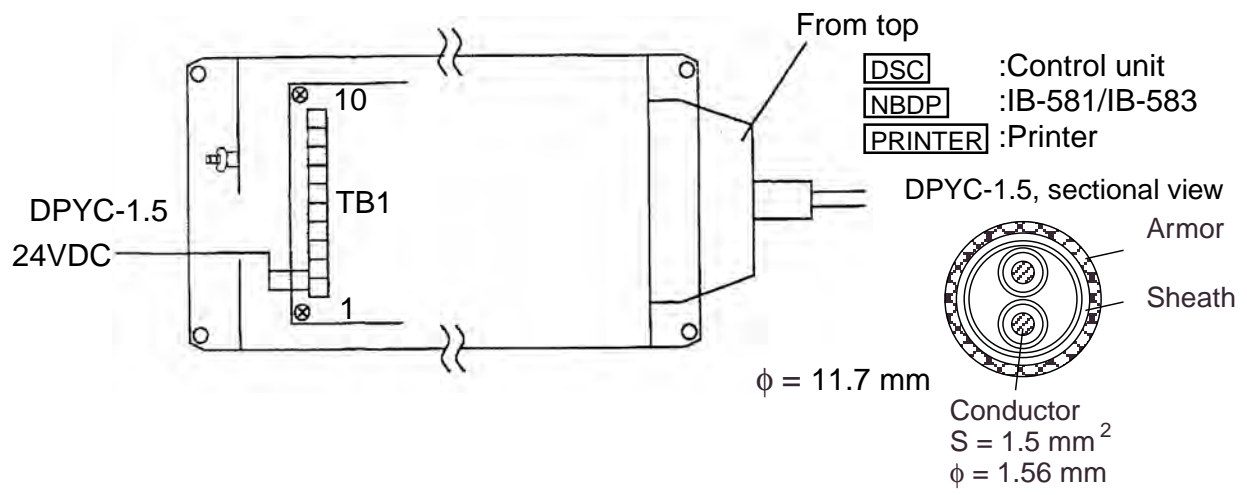

2.3 Connection of AC-DC Power Supply Unit (option)

When connecting to an AC and DC ship's mains, the optional AC-DC power supply unit PR-300 (FS-1570) or PR-850A (FS-2570) is required. Attach the crimp-on lug FV5.5-S4 (local supply) to the power cable (local supply) for connection with the power supply unit.

Use the power cable having the specifications shown in the illustration below.

- Between PR-300 and FS-1570 DPYC-6 (Japan Industrial Standard) or equivalent
- Between PR-850A and FS-2570 DPYC-10 (Japan Industrial Standard) or equivalent

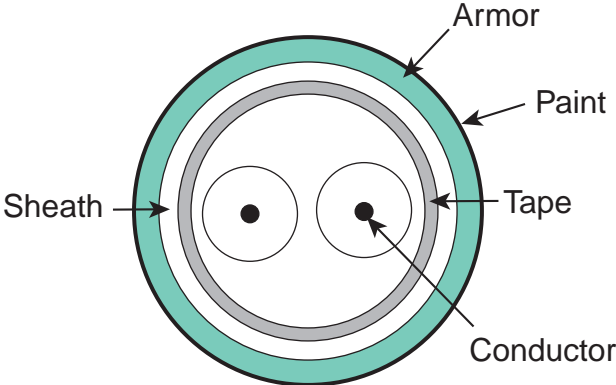

(DPYC-6)	(DPYC-10)
$S = 6.0 \text{ mm}^2$	$S = 10.0 \text{ mm}^2$
$\phi = 3.12 \text{ mm}$	$\phi = 4.05 \text{ mm}$

DPYC, sectional view

2.3.1 PR-300 for FS-1570

Both 100/110/200/220 VAC and 24 VDC are supplied to the AC-DC power supply unit PR-300. When AC input fails, DC power is supplied.

Changing tap connections

The transformer tap for input voltage has been set to 220 VAC (fuse 5A) at the factory. If necessary, change the transformer taps setting according to ship's mains.

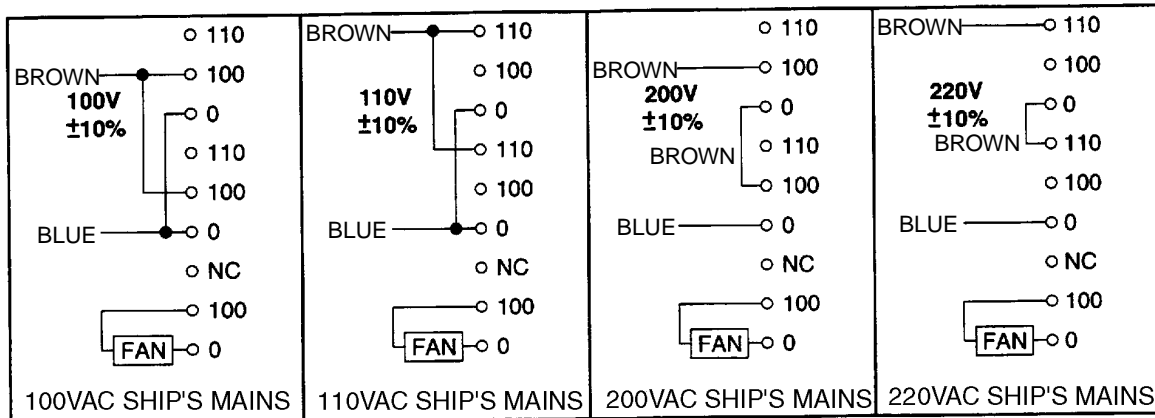

Tap connections in the PR-300

Changing the power fuse

Change the power fuse according to AC input voltage as follows.

AC ship's mains	Fuse
100/110 VAC	10 A
200/220 VAC	5 A

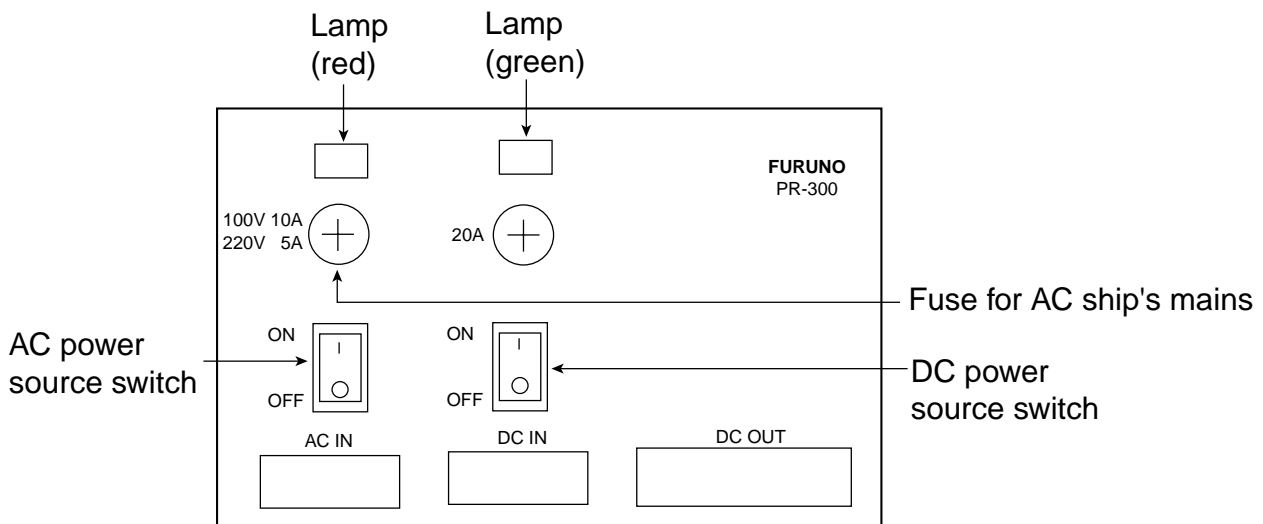

AC-DC power supply unit PR-300, rear view

Grounding

Connect a ground wire between ship's superstructure and a fixing screw on the PR-300.

2.3.2 PR-850A for FS-2570

Both 100/110/120/200/220/240 VAC and 24 VDC are supplied to the PR-850A. When AC input fails, DC power is directly supplied. For GMDSS vessels, 24 VDC power must be supplied through the radio battery.

Wiring

Connect cables to the input terminal on the front panel, using crimp-on lugs.

Selection of input voltage

The input voltage is adjustable for 100/110/120/200/220/240 VAC, and is factory-set for 220 VAC. To select other input voltages, open the top cover and change the wiring according to the figure below. After changing the input voltage, correct the front panel sticker accordingly.

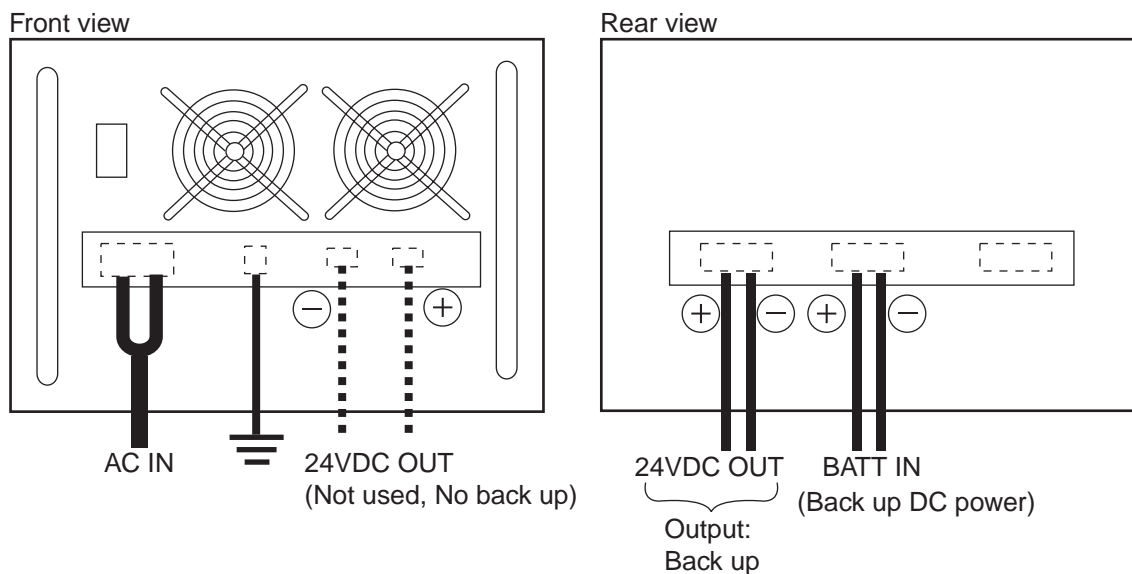

Connection of PR-850A

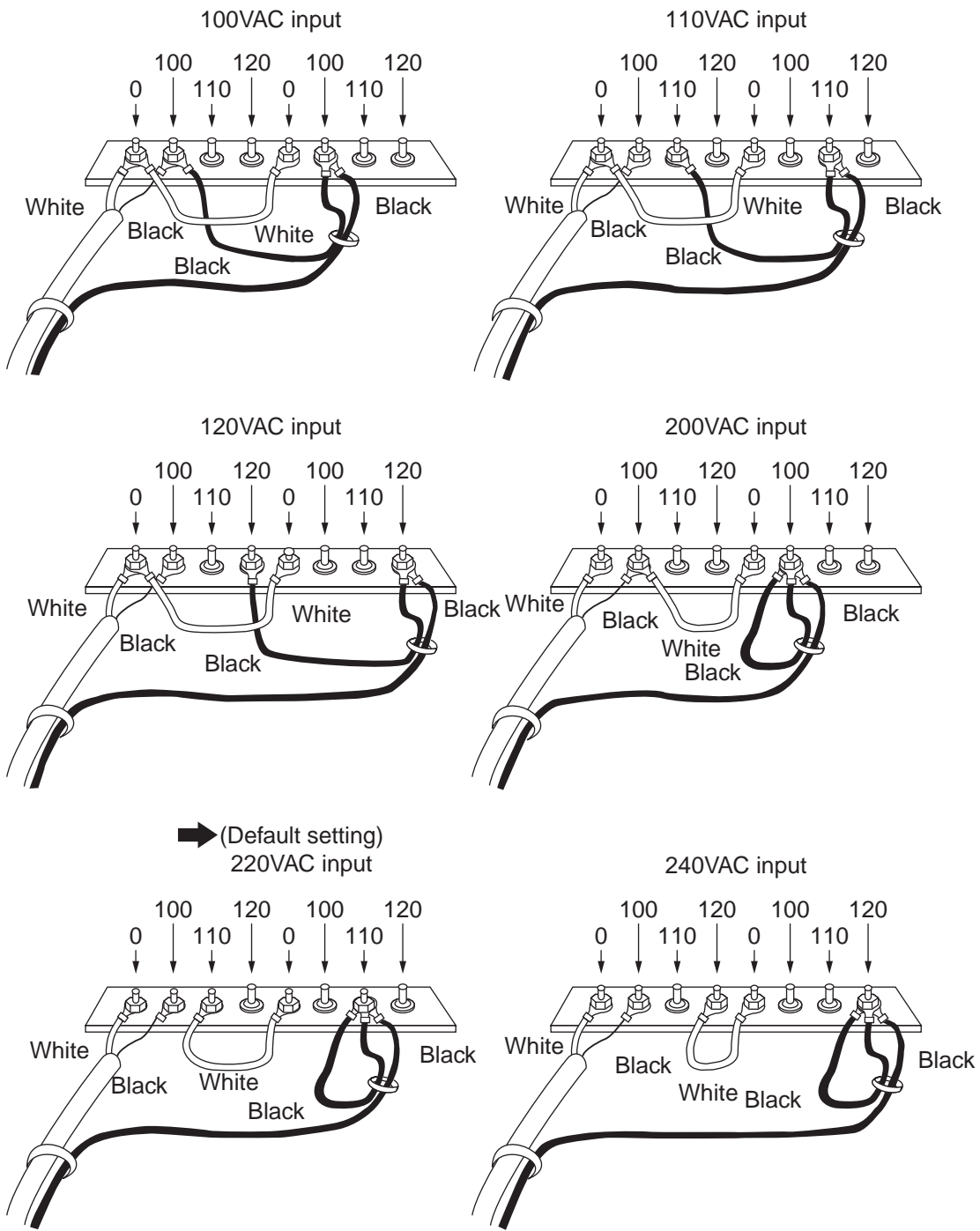

Selection of input voltage on PR-850A

Ground

Connect a ground wire between ship's superstructure and a fixing hole on the PR-850A.

2.4 Automatic Antenna Switch (option)

Connect the SSB antenna to the ANT terminal, and use the antenna cable to connect the TRX terminal and the antenna coupler (ANT terminal) as shown below. For power, connect the DPYCY-1.5 cable (Japan Industrial Standard) between the following terminals on the transceiver unit and the automatic antenna switch;

Transceiver unit (RELAY board): TB3 (or TB5) terminal (+), TB4 (or TB6) terminal (-)

Automatic antenna unit: Power terminals (+, -)

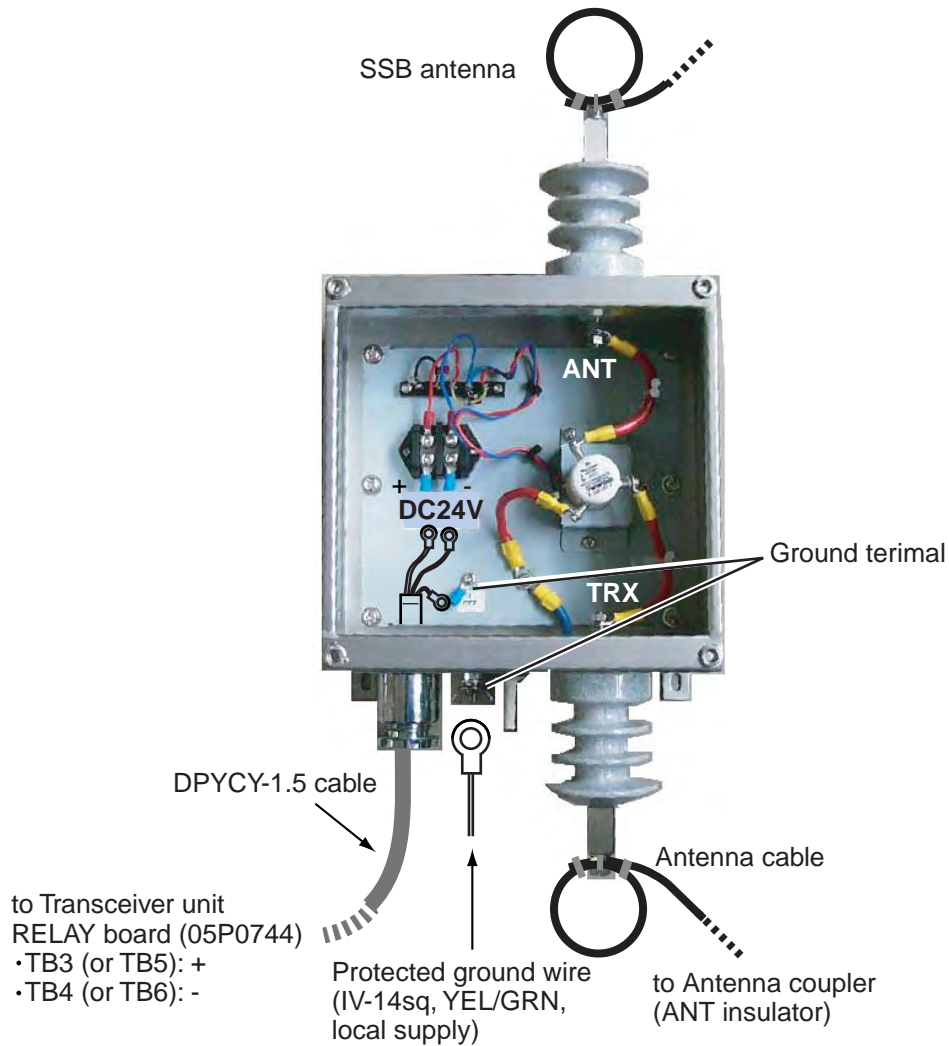

DPYCY-1.5, fabrication

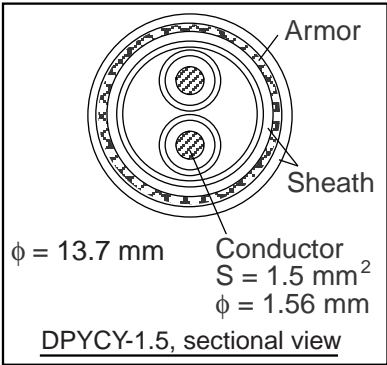
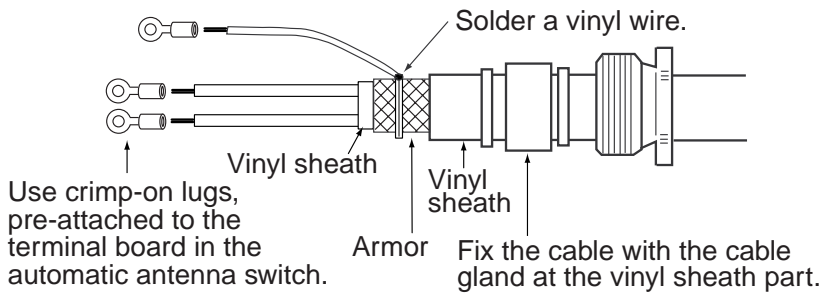

RELAY board (location)

Transceiver unit
(FS-1570T)

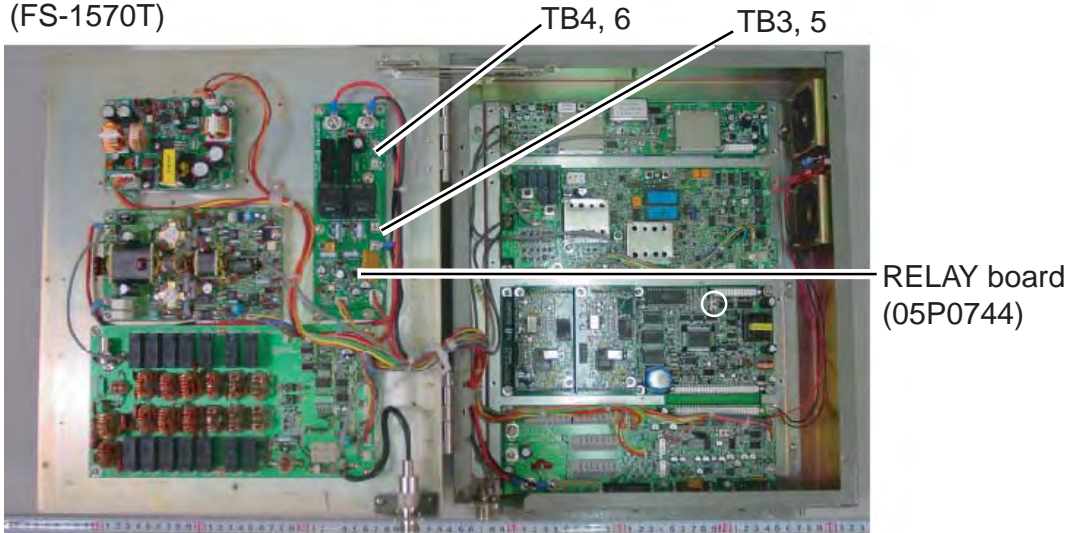

Transceiver unit
(FS-2570T)

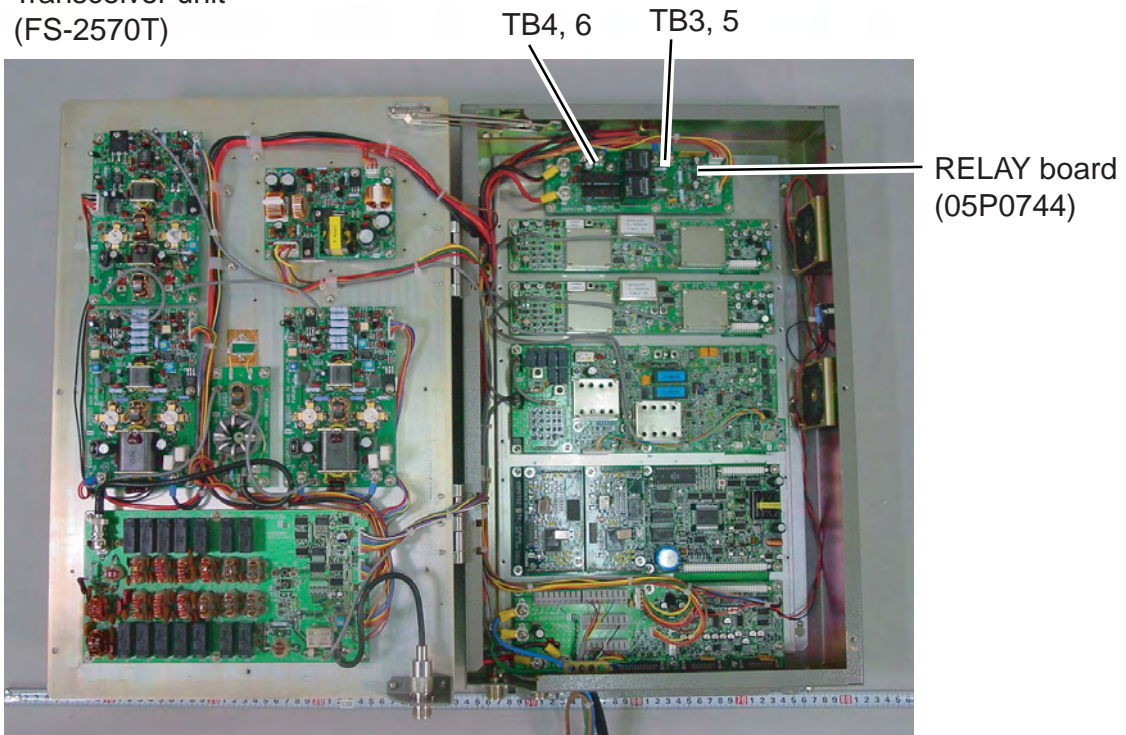

3. INITIAL SETTING

After completing the installation, check the all connection before applying the power.

Note: For the MMSI setting, ask your dealer.

3.1 Performance Check

Receiver

1. Set the unit as follows.
 - a) Speaker: ON
 - b) Squelch: OFF
 - c) AGC: FAST
 - d) Sensitivity: Max
2. Confirm that a signal can be received on each band. If noise or signal is weak, check the antenna lead-in section, coaxial cable connection and ground connections.

Transmitter

1. On each band, confirm that the antenna is automatically tuned when the [LOG/TUNE] key is pressed. Automatic tuning time of the antenna should take no longer than 15 seconds to tune, recheck antenna length.
2. Communicate with the handset, confirming that antenna current (IA) changes with voice level.

3.2 Initializing Control Unit and Transceiver Unit

The control unit is commonly used with the transceiver unit of FS-1570, FS-2570 and FS-5070. Therefore, initialize the units at installation as follows.

1. Turn on the power switch on the control unit. A while later, the radiotelephone (RT) screen appears.
2. Open the transceiver unit and press the reset switch S1 on the T-CPU board 05P0732.

TRANSCIVER FS-1570T

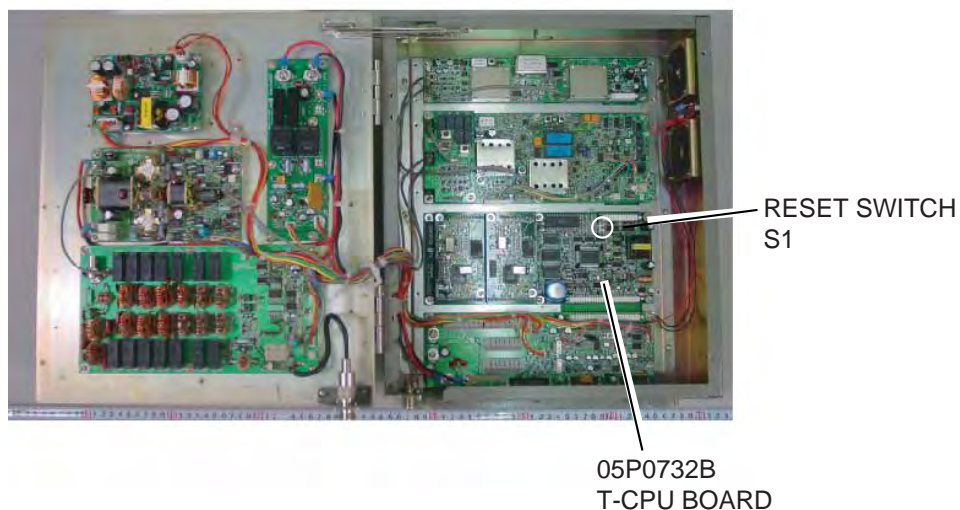

TRANSCEIVER FS-2570T

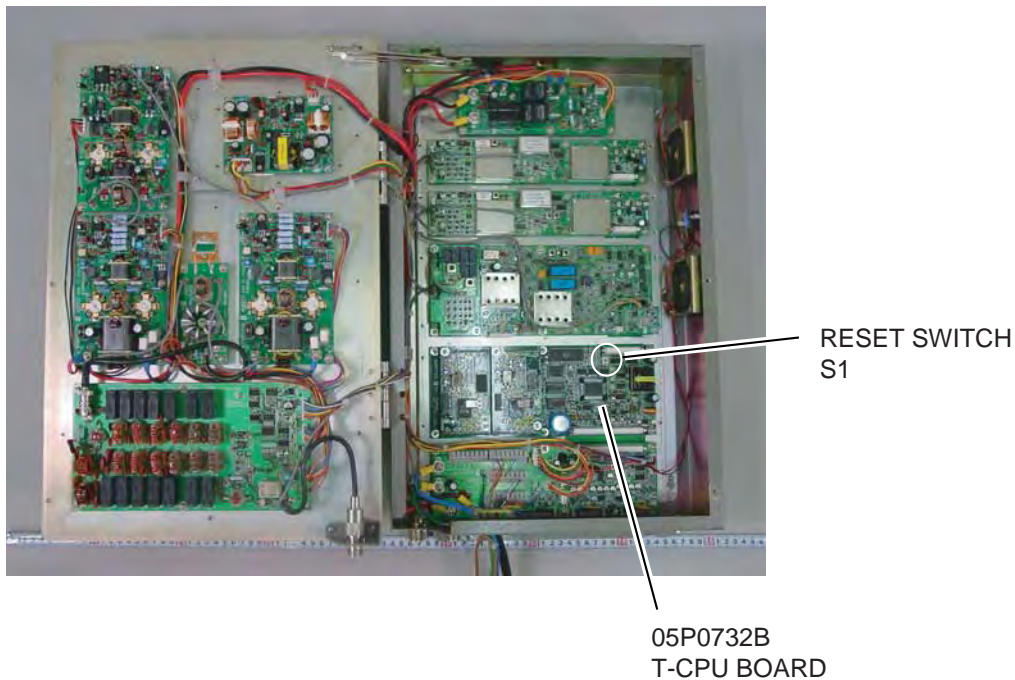

The following screen appears.

MMSI SET
MMSI CLEAR
ALL CLEAR

3. Enter the password referring to appropriate FURUNO INFORMATION. Regulations prohibit the release of the password to users.
4. Rotate the ENTER knob to select MMSI SET and press the ENTER knob.
5. Enter MMSI (Own ship's ID).
6. Turn off the power and then turn it on again.
7. Do the initialization as follows.
 - 1) Press the SET UP key to show the Set up menu.
 - 2) Enter the password.
 - 3) Select LOAD DEFAULT and press the ENTER knob.
 - 4) Select Yes and press the ENTER knob.
 - 5) Press the CANCEL key to return to the menu screen.
 - 6) Select MEM CLR from the menu screen and press the ENTER knob.
 - 7) Select LOAD DEFAULT and press the ENTER knob.
 - 8) Select Yes and press the ENTER knob.
 - 9) Press the CANCEL key to return to the menu screen.
8. Turn off the power at the control unit.

Note: If your system has two control units, do the steps 6) to 9) in step 7 from the second control unit.

3.3 Manual 2182 kHz Tuning Preset

For safety measure, it is required that 2182 kHz be tunable both automatically and manually. The setup to enable manual tuning, in the event the antenna tuner system fails, is made with the DIP switches in the antenna coupler. Call a coast station and tell your situation. Be sure not to transmit during silent period (00 to 03 min. 30 to 33 min. of every hour).

1. Remove the top cover of the antenna coupler. Set the S1 switch (Coupler Board) to AUTO.

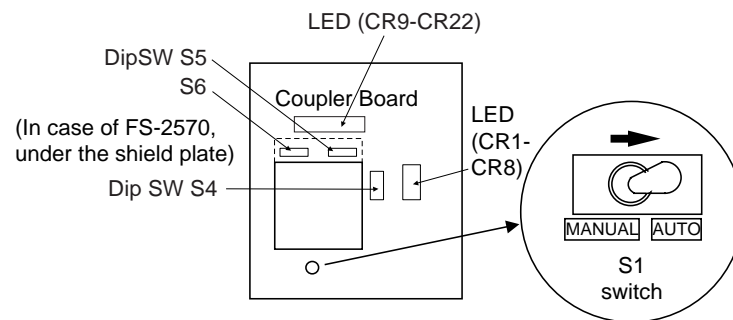

S1 switch on the COUPLER Board

2. Turn the transceiver unit on.
3. Press the [1/RT/2182] key down for two seconds.

4. Press the [LOG/TUNE] key. "TUNE" appears on the LCD. "TUNING: OK" appears when tuning is completed. Record the status (on or off) of LEDs CR1 – CR22 (on the COUPLER Board).
5. Set S1 switch to MANUAL.
6. Set S4, S5, S6 DIP switches so that LEDs become the status is the same as in step 4. The relations between the DIP switch and LED are shown on the next page. When a DIP switch is turned on, the appropriate LED lights.

DIP switch		LED No.	LED status
S4	#8	CR1	
	#7	CR2	
	#6	CR3	
	#5	CR4	
	#4	CR5	
	#3	CR6	
	#2	CR7	
	#1	CR8	
S5	#8	CR9	
	#7	CR10	
	#6	CR11	
	#5	CR12	
	#4	CR13	
	#3	CR14	
	#2	CR15	
	#1	CR16	
S6	#8	CR17	
	#7	CR18	
	#6	CR19	
	#5	CR20	
	#4	CR21	
	#3	CR22	

7. Return the S1 switch to AUTO, confirming that LEDs do not change. If different, repeat step 6.
8. Set the S1 switch to MANUAL.
9. Making sure it is not silent time, communicate with the handset. Confirm that IA changes with voice level.
10. Set the S1 switch to AUTO. Close the cover of the antenna coupler.

For technician

Please pass on the following information to the customer.

- When the auto tuning circuit is broken, transmission is available by the manual tuning (setting the S1 switch to MANUAL).
- Do not change the settings of DIP switch in the antenna coupler.

3.4 System Setup

Enter system settings as below after the installation. To prevent accidental transmission of the distress alert, disconnect the antenna. These settings should be entered by a qualified technician. The installer enters system settings on the System Setup menu. A password is required to access this menu. Under no circumstances shall the operator access the System Setup menu.

3.4.1 Opening the System Setup menu (DSC)

1. Press the [SETUP] key to display the Setup menu.
2. Rotate the [ENTER] knob to select "SYS SETUP".
3. Enter the password referring to appropriate FURUNO INFORMATION to display the System setup menu. The password cannot be informed customers by statute.

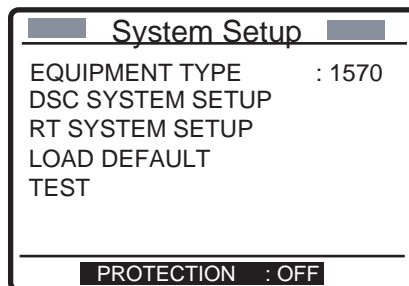

System setup menu

3.4.2 DSC SYSTEM menu

Choose "DSC SYSTEM SETUP" on the System setup menu, and then press the [ENTER] knob to show the DSC System setup menu.

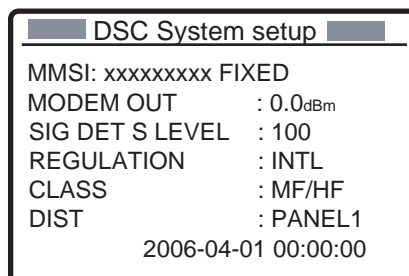

DSC System Setup menu

MODEM OUT

Adjust the level of the modem output for DSC board (DSC modem, NBDP modem). Normally, this setting is not required.

SIG DET S LEVEL

SIG DET S LEVEL judges whether the DSC frequency to use to send a DSC message is in use or not. The DSC message is not transmitted when the signal strength on the DSC frequency is higher than that set here. When the DSC frequency becomes clear, the DSC message is automatically transmitted. The setting range is OFF –255 and the default setting is 100.

1. Rotate the [ENTER] knob to select “SIG DET S LEVEL”.
2. Press the [ENTER] knob to display the S LEVEL pop-up window.

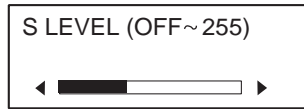

SIG DET S LEVEL pop-up window

3. Rotate the [ENTER] knob to adjust the indicator bar. Too low a setting stops transmission of a DSC message because it detects noise on the DSC frequency. Alternately, too high a setting transmits the DSC message though low signal level is present on the DSC frequency used.
4. Press the [ENTER] knob to finish.

REGULATION

Set the regulation to be used.

1. Rotate the [ENTER] knob to select “REGULATION”.
2. Press the [ENTER] knob.



Regulation pop-up window

3. Rotate the [ENTER] knob to select “INTL” or “RUSSIA”. Only for Russia registry, select “RUSSIA”.
4. Press the [ENTER] knob to finish.

DIST

Shows the last transmitted DISTRESS information.

3.4.3 RT System setup

Choose "RT SYSTEM SETUP" on the System setup menu, and then press the [ENTER] knob to show the RT (Radio Telephone) System setup menu.

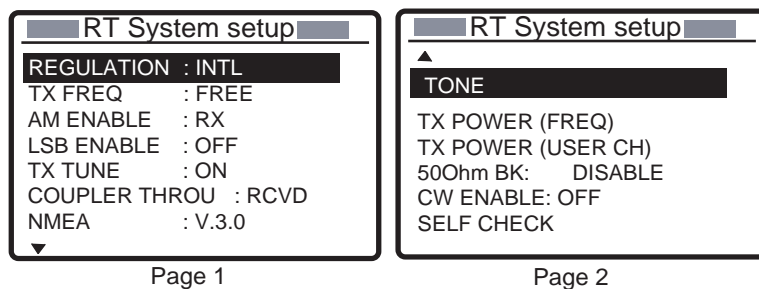

RT Setup menu

3.4.4 System setting of RT

Set the RT similarly with DSC. Do the setting at System setup menu at the transceiver unit.

Item	Description		Setting
REGULATION	Select the national regulation to change the frequency, user channel, etc.		INTL
TX FREQ	Select the frequency to transmit. FREE: Any frequency can be set. MARINE/USER: Can use the frequency and radio type set in the marine band and the user channel. ITU/USER: Can use the frequency and radio type set in the user channel or permitted with ITU channel. USER: Can use the frequency and radio type set in the user channel.		FREE , MARINE/USER, ITU/USER, USER
AM ENABLE	Select the method of AM (H3E). OFF: TX/RX are not available. TRX: TX/RX are available. RX: RX only is available.		OFF, TRX, RX
LSB ENABLE	Select ON to transmit/receive LSB.		OFF , ON
TX TUNE	Turn the tuning of the antenna coupler on/off.		OFF, ON
COUPLER THROU (through)	Selects the route on receiving. (OFF: Runs via antenna coupler.)		OFF, RCVD , DUPLEX
NMEA	Choose the acceptable NMEA version.		V.3.0 , COMPATIBLE
TONE	For maintenance.		
TX POWER (FREQ) TX POWEER (USER CH)	TX MODE	Select the mode to set the TX power.	
	TX FREQ (CH)	Select the frequency to set.	2182.0 kHz
	TX POWER	Select the output level to set TX power.	HIGH , MID, LOW, TUNE
	TX POWER ADJ	Set the TX power.	0-255, 240
	TX TONE	Transmit TONE.	OFF , ON
	LOAD DEFAULT	Restore TX power settings to default.	YES, NO
50 Ohm BK	Selects the installation situation of the 50 ohms BK.		ENABLE , DISABLE

Bold: default setting

3.5 Setting DIP Switches

Location of DIP Switches

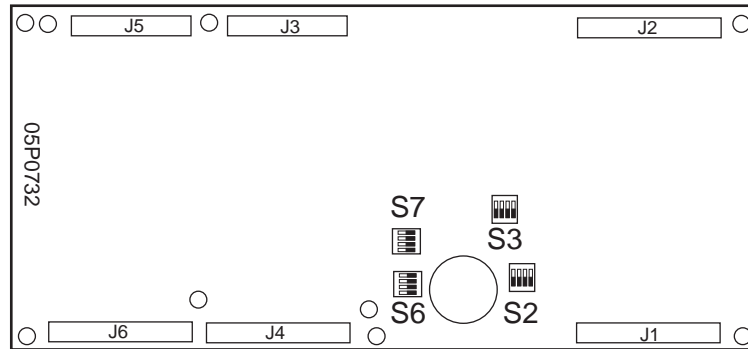

CPU Board (05P0732)

IEC (NMEA)/MIF data receiving line (S2)

IEC (NMEA)

	RS-422	Current Loop
S2-#1	ON	OFF

Bold: default setting

MIF

	RS-422/232C		Current Loop
	RS-422	RS-232C	
S2-#3	ON	-	OFF
S3-#1, 2	ON	OFF	-
S3-#3, 4	OFF	ON	-

Bold: default setting

Note: S2-#4 is no used.

IC-302-DSC

Set to Current Loop for IC-302 connection.

S6				S7			
#1	#2	#3	#4	#1	#2	#3	#4
OFF	OFF	OFF	OFF	ON	ON	ON	ON

Bold: default setting

3.6 Preamp Setting (For FAX-5)

When using the preamp for the watch receiver antenna, set J3 on the W/R Board to ACTIVE in the transceiver unit.

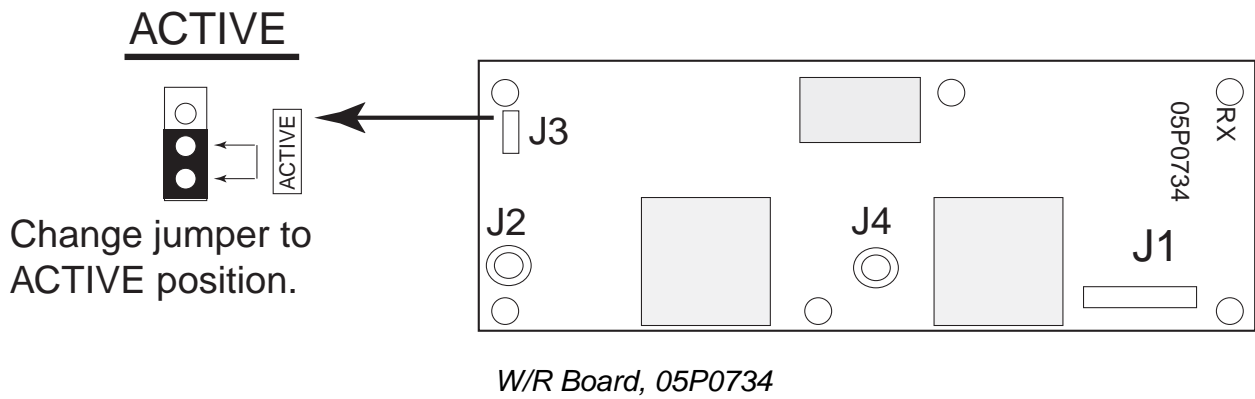

4. OPTION KIT

4.1 DSC Routine Frequency Board

For FS-2570, the W/R Board 05P0734A (option) enables reception of DSC routine frequencies without the SSB radiotelephone connection. For complete modification, the whip antenna for DSC routine frequency is necessary.

- Necessary Parts :W/R2 Board Kit, Type :OP05-99, Code No. :005-951-840

Name	Type	Code No.	Qty	Remarks
W/R Board	05P0734A	001-005-320	1	
Coaxial plug	FM-MP-7	000-161-293-10	1	
Cable assy. with mini-pin	L-500	000-165-876-10	1	
Cable assy. with mini-pin	L-770	000-165-887-10	1	

Mounting

1. When using the preamplifier, set J3 on W/R board in the kit to ACTIVE (See previous page). In this section, W/R Boards are described as below.
 - Pre-attached W/R Board: W/R 1
 - Optional W/R Board: W/R 2
2. Open the transceiver unit.
3. Remove the shield cover at where the W/R 2 board should be fixed in the transceiver unit.
4. Insert the W/R 2 Board to the position shown below so that J1 connector on the W/R 2 Board mates with to P1201 in the transceiver unit and fasten it with six screws.

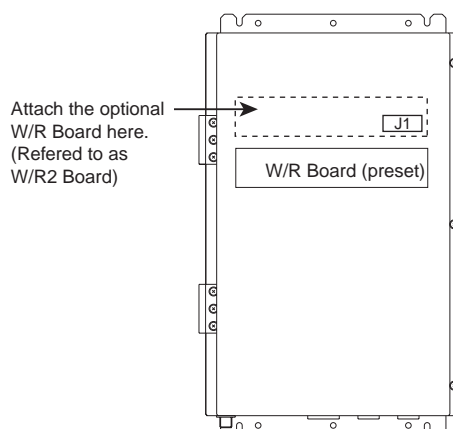

FS-2570T, cover opened

5. Insert the mini-pin plug, coming from the coaxial connector ANT W/R2, to J2 on the W/R2 board.
6. Connect the cable assy with mini-pin (L-500) between J4 on the W/R2 board and J7 on the TX-RX board 05P0733.
7. Pass the above cable assy through the notch on the shield cover removed at step 3, and then attach the shield cover.

How to use SSB antenna coupler for DSC routine frequency receive

To use the SSB antenna coupler for routine watch keeping, the following modification is necessary.

Note: When transmitting, DSC routine frequency cannot be received.

1. Open the transceiver unit.
2. Remove the shield cover from the TX FIL Board (05P0736).
3. Cut the jumper JP2 on the TX FIL Board.
4. Solder the jumper wire to JP1.

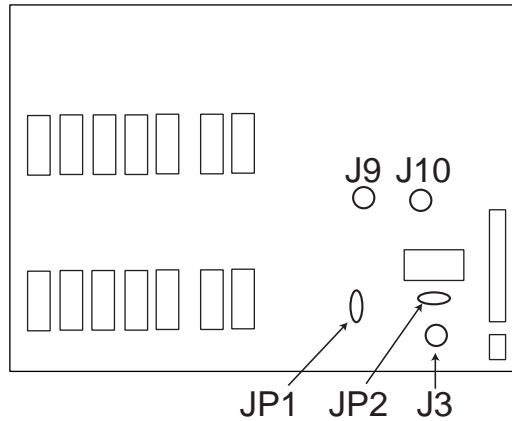

TX_FIL Board, 05P0736

5. Disconnect the coaxial cable from J3, and then reconnect it to J10.
6. Remove the shield cover of the W/R2 Board (05P0734A).
7. Run the cable assy. with mini-pin (L-500) between J7 on TX-RX Board and J4 on W/R 2 Board.

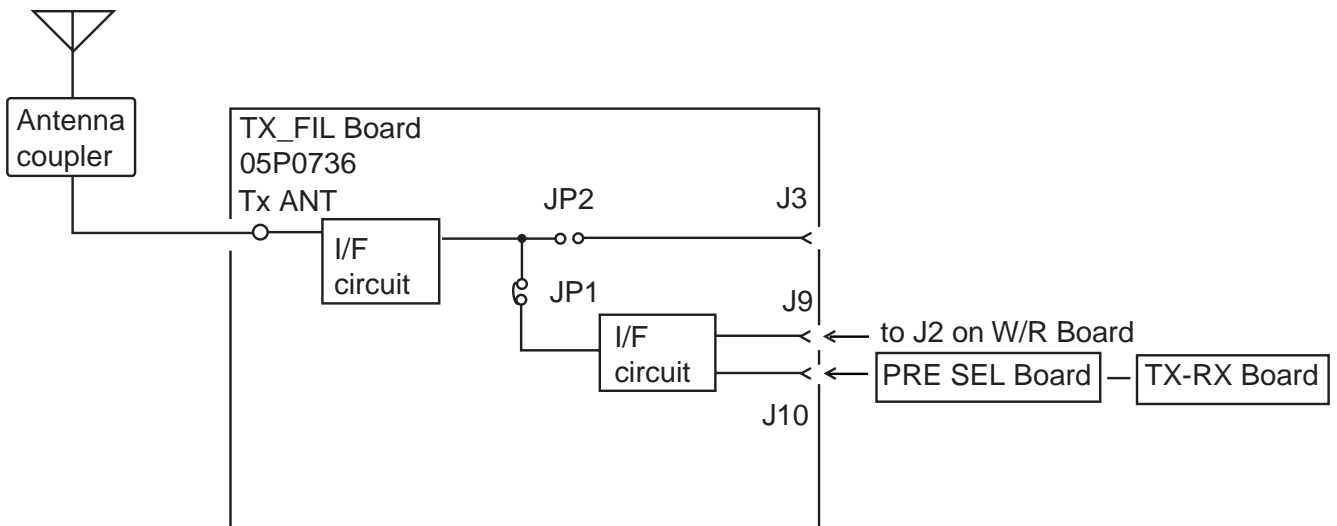

TX_FIL Board

8. Run the cable assy. with mini-pin (L-770) between J9 on the TX-FIL Board and J2 on the W/R 2 Board.
9. Remount the shield cover, and then close the transceiver unit cover.

4.2 Connecting of NBDP Terminal Unit OP05-96 (IB-581)/OP05-100 (IB-583)

To use this equipment for the telex, the NBDP terminal unit is required.

Name: NBDP terminal set, Type: OP05-96, Code No.: 000-056-949

Name	Type	Code No.	Qty	Remarks
Terminal unit	IB-581-02	000-043-350	1 set	w/installation materials
DSP Board	OP05-97	005-951-820	1	05P0751A

Name: NBDP terminal set, Type: OP05-100, Code No.: 000-056-956

Name	Type	Code No.	Qty	Remarks
Terminal unit	IB-583	000-043-435	1	w/installation materials
DSP Board	OP05-97	005-951-820	1 set	05P0751A

Inserting the DSP Board

1. Open the cover of the transceiver unit.
2. Remove the shield cover from the T-CPU Board (05P0732).
3. Attach the DSC Board (supplied) on J5 and J6 of the T-CPU Board.

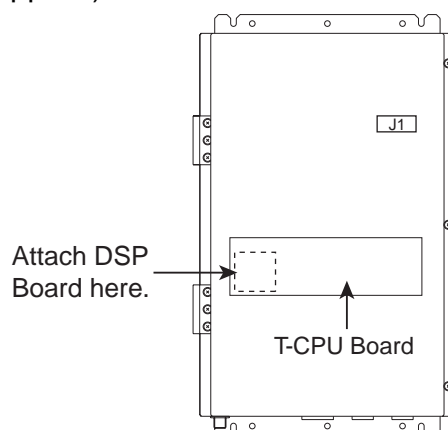

Location of DSP Board

4. Remount the shield cover.
5. Close the cover of the transceiver unit.

Mounting location for terminal unit

- Leave sufficient space around the unit for operation and maintenance.
- The temperature and humidity of the mounting location should be stable and moderate.
- Keep the unit away from the high power radiotelephone and its feeder wire so that RFI (Radio Frequency Interference) is minimum.

Mounting the IB-581

Refer to the outline drawing at the back of this manual.

1. Fix the hanger by using five tapping screws (supplied with option kit).

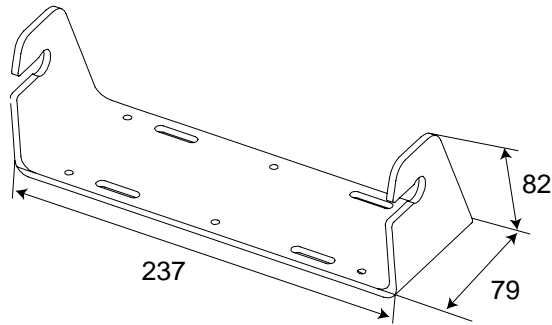

Dimensions of hanger

2. Attach all connectors to the bottom of the terminal unit.

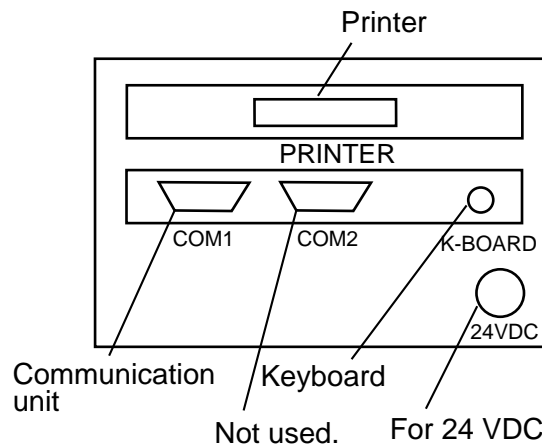

Terminal unit (IB-581), bottom view

3. Screw knobs to fix the terminal unit to the hanger.
4. Use the 17JE-573-10 to connect the NBDP port of the control unit and COM1 port of the NBDP terminal unit.

Keyboard

1. Attach the labels for NBDP and the compass safe distance to the appropriate locations shown below.

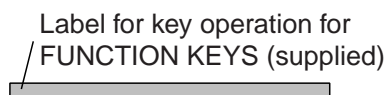

LABEL FOR COMPASS SAFE DISTANCE
(supplied)

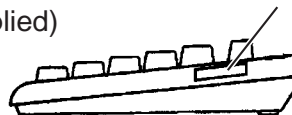

2. Attach four fasteners (small, supplied with the optional kit) to the bottom of the keyboard.
3. Attach four fasteners (large, supplied with the optional kit) to the small fasteners used in step 3.
4. Peel the paper from four fasteners.
5. Fix the keyboard to the mounting location.

Mounting the IB-583

1. Fix the hanger by using four tapping screws (supplied with option kit).

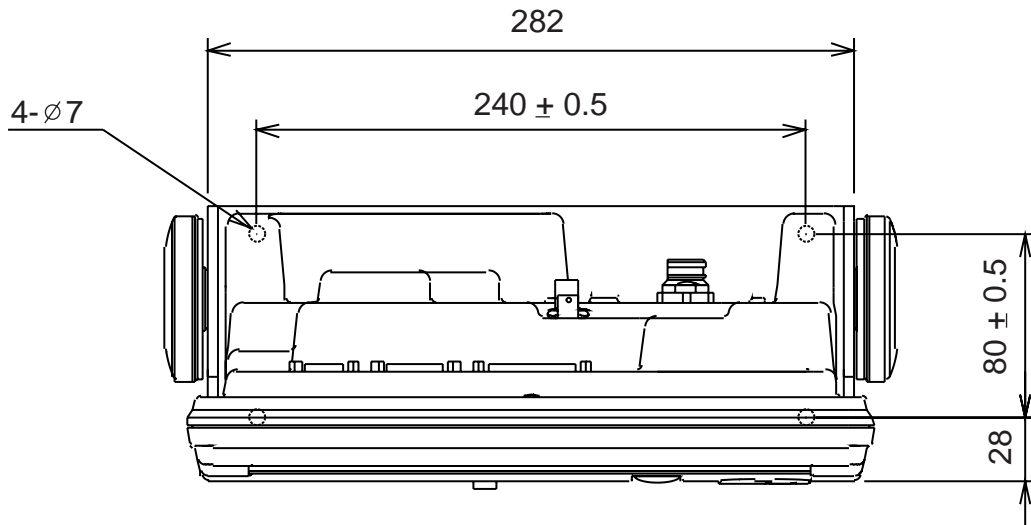

Dimensions of IB-583

2. Tighten two knobs to the terminal unit loosely.
3. Mount the terminal unit to the hanger, and then fasten knobs.
4. Attach the earth wire 08S0087 to the earth terminal at the back of the terminal unit.
5. Use the cable assy 05S9351 to connect NBDP port on the control unit and DTE port on the terminal unit.

Keyboard

1. Attach the function key label NBDP to the location shown below.

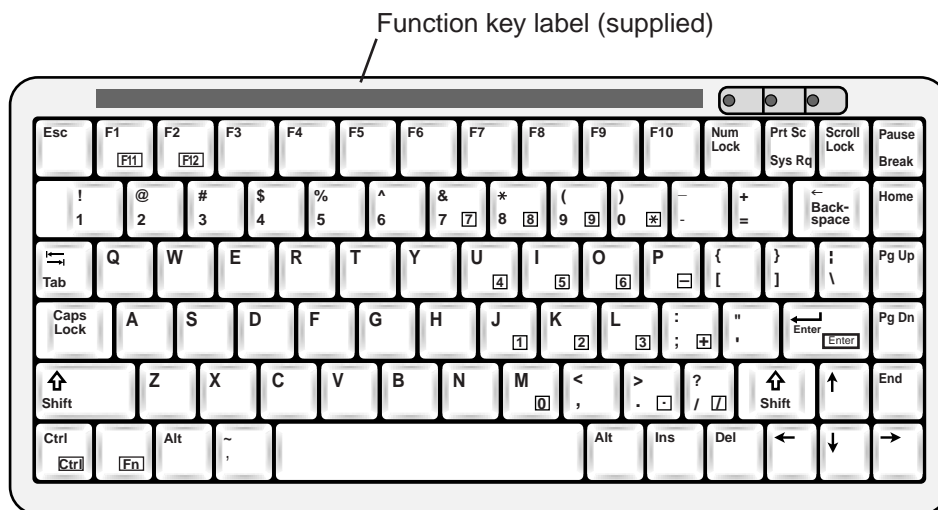





2. Attach four fasteners (small, supplied with the optional kit) to the bottom of the keyboard.
3. Attach four fasteners (large, supplied with the optional kit) to the small fasteners used in step 3.
4. Peel the paper from four fasteners.
5. Fix the keyboard to the mounting location

This page is intentionally left blank.

PACKING LIST

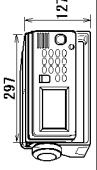
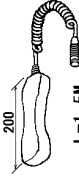
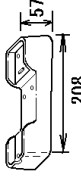
FS-2571C-J-A/FS-2571C-E-A/FS-2571C-J-A-HK

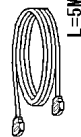
A-1

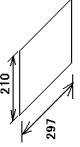
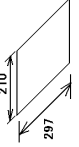
NAME	OUTLINE	DESCRIPTION/CODE No.	QTY
ユニット			
操作部 CONTROL UNIT		FS-2571C 000-057-442-00	1
付属品			
ハンドセット HANDSET		HS-2003-15 000-015-996-00	1
ハンドセットホルダ -組品 BRACKET FOR HANDSET		FP05-05510 005-951-790-00	1
付属品 ACCESSORIES		FP05-05511 005-951-920-00	1
工事材料			
INSTALLATION MATERIALS			
ケーブル組品 CABLE ASSY.		17JE23150-02 (08C) 5M 000-146-015-00	1
工事材料 INSTALLATION MATERIALS		CP05-08801 005-951-930-00	1
図書			
DOCUMENT			
避難警報カード (HF) HF DISTRESS ALERT FLOW		*52-00102-* 000-809-271-1*	1
避難警報カード (VHF/MF) VHF/MF DISTRESS ALERT FLOW		*52-00101-* 000-809-269-1*	1

コート番号末尾の[**]は、選用品の代表コードを表します。
CODE NUMBER ENDING WITH "**" INDICATES THE CODE NUMBER OF REPRESENTATIVE MATERIAL.



型式/コート番号が2段の場合、下段より上段に代わる過渡期品であり、どちらが入っています。なお、品質は変わりません。
TWO TYPES AND CODES MAY BE LISTED FOR AN ITEM. THE LOWER PRODUCT MAY BE SHIPPED IN PLACE OF THE UPPER PRODUCT. QUALITY IS THE SAME.
(略図の寸法は、参考値です。 DIMENSIONS IN DRAWING FOR REFERENCE ONLY.)

05ED-X-9852

PACKING LIST

FS-2571C-J-N/FS-2571C-E-N/FS-2571C-J-N-HK

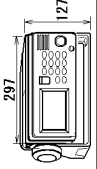
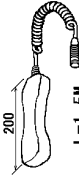
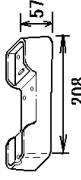
A-2

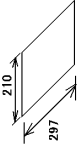
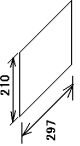
NAME	OUTLINE	DESCRIPTION/CODE No.	QTY
ユニット			
操作部 CONTROL UNIT		FS-2571C 000-057-442-00	1
付属品			
ハンドセット HANDSET		HS-2003-15 000-015-996-00	1
ハンドセットホルダ -組品 BRACKET FOR HANDSET		FP05-05510 005-951-790-00	1
付属品 ACCESSORIES		FP05-05511 005-951-920-00	1
工事材料			
INSTALLATION MATERIALS			
工事材料 INSTALLATION MATERIALS		CP05-08801 005-951-930-00	1
図書			
DOCUMENT			
避難警報カード (HF) HF DISTRESS ALERT FLOW		*52-00102-* 000-809-271-1*	1
避難警報カード (VHF/MF) VHF/MF DISTRESS ALERT FLOW		*52-00101-* 000-809-269-1*	1

コート番号末尾の[**]は、選用品の代表コードを表します。
CODE NUMBER ENDING WITH "**" INDICATES THE CODE NUMBER OF REPRESENTATIVE MATERIAL.





型式/コート番号が2段の場合、下段より上段に代わる過渡期品であり、どちらが入っています。なお、品質は変わりません。
TWO TYPES AND CODES MAY BE LISTED FOR AN ITEM. THE LOWER PRODUCT MAY BE SHIPPED IN PLACE OF THE UPPER PRODUCT. QUALITY IS THE SAME.
(略図の寸法は、参考値です。 DIMENSIONS IN DRAWING FOR REFERENCE ONLY.)

05ED-X-9853

CODE NO.	005-952-180-00	050Z-X-9402-8
TYPE	CP05-08802	1/1

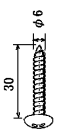
工事材料表

INSTALLATION MATERIALS



番号 NO.	名称 NAME	略図 OUTLINE	型名/規格 DESCRIPTIONS	数量 Q'TY	用途/備考 REMARKS
1	+1539カネジ 1/2 SELF-TAPPING SCREW		6X30 SUS304 CODE NO. 000-162-614-10	6	
2	コネクタ (M) COAXIAL CONNECTOR *M TYPE*		GSC-100/MP-7 CODE NO. 000-166-977-10	2	
3	ポリカーボネート POLYCARBONATE WASHER		M6 P.C CODE NO. 000-168-259-10	6	
4	コネクタ (M2) CONNECTOR (O-SUB)		XM2S-2513-S014 CODE NO. 001-115-850-10	1	

型式/コード番号が2股の場合、下段より上段に代わる通線製品であり、どちらが入っています。なお、品質は変わりません。
TWO TYPES AND CODES MAY BE LISTED FOR AN ITEM. THE LOWER PRODUCT MAY BE SHIPPED IN PLACE OF THE UPPER PRODUCT.
QUALITY IS THE SAME.
(略図の寸法は、参考値です。 DIMENSIONS IN DRAWING FOR REFERENCE ONLY.)

CODE NO.	100-055-238-00	05GS-X-9402-4
TYPE	CP05-05700	1/1

工事材料表

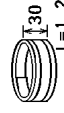

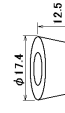
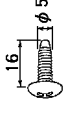

INSTALLATION MATERIALS

番号 NO.	名称 NAME	略図 OUTLINE	型名/規格 DESCRIPTIONS	数量 Q'TY	用途/備考 REMARKS
1	7-ス銅板 COPPER STRAP		04S40801 30X1200X0.3 CODE NO. 000-572-187-00	1	
2	ブラインドキャップ BLIND CAP		05-039-6325-0 ROHS CODE NO. 100-164-380-10	1	
3	パイプシャム PIPE SHAL		05S0938 CODE NO. 000-130-472-10	1	
4	+1539カネジ 1/2 SELF-TAPPING SCREW		5X16 SUS304 CODE NO. 000-162-607-10	4	

型式/コード番号が2股の場合、下段より上段に代わる通線製品であり、どちらが入っています。なお、品質は変わりません。
TWO TYPES AND CODES MAY BE LISTED FOR AN ITEM. THE LOWER PRODUCT MAY BE SHIPPED IN PLACE OF THE UPPER PRODUCT.
QUALITY IS THE SAME.
(略図の寸法は、参考値です。 DIMENSIONS IN DRAWING FOR REFERENCE ONLY.)

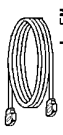
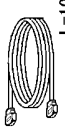
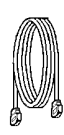
FURUNO







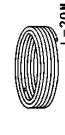

工事材料表

SSB RADIO TELEPHONE FS-1570/2570		CODE NO.	05DZ-X-9401-1	1/1	
		TYPE			
番号 NO.	名称 NAME	略図 OUTLINE	型名/規格 DESCRIPTIONS	数量 QTY	用途/備考 REMARKS
1	ケーブル組品 CABLE ASSY.		17JE23150-02 (DBC) 5M CODE NO. 000-146-015-00	1	選択 TO BE SELECTED
2	ケーブル組品 CABLE ASSY.		17JE23150-02 (DBC) 10M CODE NO. 000-146-016-00	1	選択 TO BE SELECTED
3	ケーブル組品 CABLE ASSY.		17JE23150-02 (DBC) 20M CODE NO. 000-146-017-00	1	選択 TO BE SELECTED
4	ケーブル組品 CABLE ASSY.		17JE23150-02 (DBC) 30M CODE NO. 000-146-018-00	1	選択 TO BE SELECTED
5	ケーブル組品 CABLE ASSY.		17JE23150-02 (DBC) 40M CODE NO. 000-146-019-00	1	選択 TO BE SELECTED
6	ケーブル組品 CABLE ASSY.		17JE23150-02 (DBC) 50M CODE NO. 000-146-020-00	1	選択 TO BE SELECTED

型式/コード番号が2段の場合、下段より上段に代わる通線部品であり、どちらが入っています。なお、品質は変わりません。
TWO TYPES AND CODES MAY BE LISTED FOR AN ITEM. THE LOWER PRODUCT MAY BE SHIPPED IN PLACE OF THE UPPER PRODUCT. QUALITY IS THE SAME.
(略図の寸法は、参考値です。)

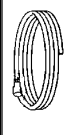
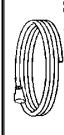
FURUNO

工事材料表

FS-1570/2570		CODE NO.	05DS-X-9403-3	1/1	
		TYPE			
番号 NO.	名称 NAME	略図 OUTLINE	型名/規格 DESCRIPTIONS	数量 QTY	用途/備考 REMARKS
1	ケーブル組品 5P TWISTED PAIR CABLE		05S0793-0 *10M* 05S0793-0 *10M* CODE NO. 000-125-984-10 000-125-984-00	1	選択 TO BE SELECTED
2	ケーブル組品 5P TWISTED PAIR CABLE		05S0793-0 *20M* 05S0793-0 *20M* CODE NO. 000-125-986-10 000-125-986-00	1	選択 TO BE SELECTED
3	ケーブル組品 5P TWISTED PAIR CABLE		05S0793-0 *30M* 05S0793-0 *30M* CODE NO. 000-125-987-10 000-125-987-00	1	選択 TO BE SELECTED
4	ケーブル組品 5P TWISTED PAIR CABLE		05S0793-0 *40M* 05S0793-0 *40M* CODE NO. 000-125-988-10 000-125-988-00	1	選択 TO BE SELECTED
5	ケーブル組品 5P TWISTED PAIR CABLE		05S0793-0 *50M* 05S0793-0 *50M* CODE NO. 000-125-989-10 000-125-989-00	1	選択 TO BE SELECTED
6	ケーブル組品 CABLE ASSY.		05S0949 L-10M CODE NO. 000-130-484-00	1	選択 TO BE SELECTED
7	ケーブル組品 CABLE ASSY.		05S0949 L-20M CODE NO. 000-130-485-00	1	選択 TO BE SELECTED
8	ケーブル組品 CABLE ASSY.		05S0949 L-30M CODE NO. 000-130-486-00	1	選択 TO BE SELECTED
9	ケーブル組品 CABLE ASSY.		05S0949 L-40M CODE NO. 000-130-487-00	1	選択 TO BE SELECTED
10	ケーブル組品 CABLE ASSY.		05S0949 L-50M CODE NO. 000-130-488-00	1	選択 TO BE SELECTED





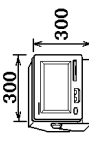
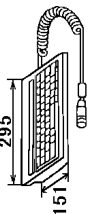
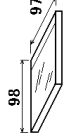
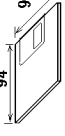
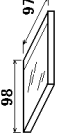

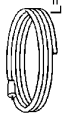
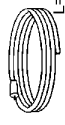

型式/コード番号が2段の場合、下段より上段に代わる通線部品であり、どちらが入っています。なお、品質は変わりません。
TWO TYPES AND CODES MAY BE LISTED FOR AN ITEM. THE LOWER PRODUCT MAY BE SHIPPED IN PLACE OF THE UPPER PRODUCT. QUALITY IS THE SAME.
(略図の寸法は、参考値です。)

PACKING LIST
IB-581 (DP-6)

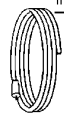
NAME UNIT		OUTLINE		DESCRIPTION/CODE No.	QTY
ユニット					
ターミナルユニット			300	IB-581-02-2.5GY	1
付属品	ACCESSORIES			000-055-405 **	
ミニキーボード			295 151	BTG-5100C PS/2	1
MINI KEYBOARD				004-442-400	
フロッピーディスク (書き込み品)			98 97	05-501-891	1
FLOPPY DISK				004-447-090	
フロッピーディスク			94 90	MFZ-HD DOS18 B40P	1
Floppy Disk				000-141-772	(*1)
FDケース			98 97	FD3-001	1
FLOPPY DISK CASE				000-150-735	(*2)

注記) 1.コード番号末尾の「*」は、共通機種名を表す。
CODE NUMBER ENDED BY "*" INDICATES THE NUMBER OF TYPICAL MODEL.
2. (*1), (*2)は、セットされています。
(*1) and (*2) are a set.

FURUNO

CODE NO.		TYPE		0505-X-9408 -1		1/1
FS-1570/2570						
工事材料表	INSTALLATION MATERIALS	略図	OUTLINE	型名/規格	DESCRIPTIONS	数量
番号	名称	略図	OUTLINE	型名/規格	DESCRIPTIONS	数量
1	ケーブル組品 CABLE ASSY.		L=10M	05S0462 L-10M		1
2	ケーブル組品 CABLE ASSY.		L=20M	05S0462 L-20M		1
3	ケーブル組品 CABLE ASSY.		L=30M	05S0462 L-30M		1
4	ケーブル組品 CABLE ASSY.		L=40M	05S0462 L-40M		1
5	ケーブル組品 CABLE ASSY.		L=50M	05S0462 L-50M		1
6	同軸ケーブル ARMOURED COAXIAL CABLE		L=10M	RG-10/0-Y *10M*		1
7	同軸ケーブル ARMOURED COAXIAL CABLE		L=20M	RG-10/0-Y *20M*		1
8	同軸ケーブル ARMOURED COAXIAL CABLE		L=30M	RG-10/0-Y *30M*		1
9	同軸ケーブル ARMOURED COAXIAL CABLE		L=40m	RG-10/0-Y *40M*		1
10	同軸ケーブル ARMOURED COAXIAL CABLE		L=50m	RG-10/0-Y *50M*		1





(略図の寸法は、参考値です。 DIMENSIONS IN DRAWING FOR REFERENCE ONLY.)

FURUNO ELECTRIC CO., LTD.

PACKING LIST

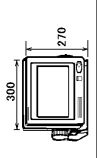

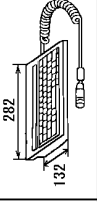
IB-583

A-10

NAME		OUTLINE		DESCRIPTION / CODE No.		QTY
UNIT						
ユニット						
ターミナルユニット		IB-583				1
TERMINAL UNIT		000-043-436-00			SP05-05001	**
予備品						
予備品		SP05-05001			(IB-583用)	1
SPARE PARTS		004-447-280-00			FP16-00600	
付属品						
フロッピーディスク組品		FP16-00601	98	97		1
FLOPPY DISK		004-439-400-00				
ミニボード		G84-4100PPAUS	282	132		1
KEYBOARD		000-172-018-10			CP16-02302	
工事材料						
工事材料		CP16-02302				1
INSTALLATION MATERIALS		004-439-390-00			CP05-08901	
工事材料						
工事材料		CP05-08901				1
INSTALLATION MATERIALS		004-447-290-00				

型式/コード番号が2段の場合、下段より上段に代わる過渡期品であり、どちらが入っています。なお、品質は変わりません。
 TWO TYPES AND CODES MAY BE LISTED FOR AN ITEM. THE LOWER PRODUCT MAY BE SHIPPED IN PLACE OF THE UPPER PRODUCT. QUALITY IS THE SAME.
 (略図の寸法は、参考値です。 DIMENSIONS IN DRAWING FOR REFERENCE ONLY.) 05DZ-X-9853

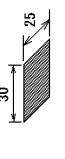
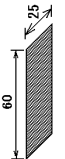
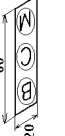
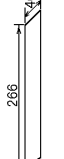
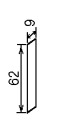
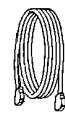
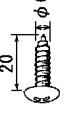
A-9

CODE NO.		16AF-X-9410-4		1/1	
TYPE					
TYPE		CP16-01150			
工事材料表					
INSTALLATION MATERIALS					
番号 NO.	名称 NAME	略図 OUTLINE	型名/規格 DESCRIPTIONS	数量 QTY	用途/備考 REMARKS
1	7-ス線 GROUNDING WIRE		08S0087-0 CODE NO. 000-108-138-00	1	
2	7フタ(3) HOOK LOOP FASTENER		16-007-6814-0 ROHS CODE NO. 100-237-670-10	4	
3	7フタ(4) HOOK LOOP FASTENER		16-007-6815-0 ROHS CODE NO. 100-237-680-10	4	
4	10マラ(1) (1MMAR) LABEL (1MMAR)		16-007-6919-0 ROHS CODE NO. 100-217-010-10	1	
5	10マラ(2) LABEL		16-011-5803-1 ROHS CODE NO. 100-248-051-10	1	
6	10マラ(3) (C.S.D) LABEL (C.S.D)		16-011-5804-0 ROHS CODE NO. 100-248-060-10	1	
7	ケーブル組品(17JE) CABLE ASSEMBLY		81-521-1204-010 17JE-573-10 ハ-ス CODE NO. 001-079-240-10 000-127-108-00	1	
8	+5V出力端子 SELF-TAPPING SCREW		6X20 SUS304 CODE NO. 000-162-613-10	4	
9	電源ケーブル(D.C.用) POWER CABLE (FOR DC MAINS)		VC1F0.75X20 *3M** CODE NO. 000-112-543-00	1	

型式/コード番号が2段の場合、下段より上段に代わる過渡期品であり、どちらが入っています。なお、品質は変わりません。
 TWO TYPES AND CODES MAY BE LISTED FOR AN ITEM. THE LOWER PRODUCT MAY BE SHIPPED IN PLACE OF THE UPPER PRODUCT. QUALITY IS THE SAME.
 (略図の寸法は、参考値です。 DIMENSIONS IN DRAWING FOR REFERENCE ONLY.)

信号、電源コネクタ
SIGNAL, POWER CABLE CONNECTOR

表 1 TABLE 1

寸法区分 (mm) DIMENSIONS	公差 (mm) TOLERANCE
L ≤ 50	±1.5
50 < L ≤ 100	±2.5
100 < L ≤ 500	±3

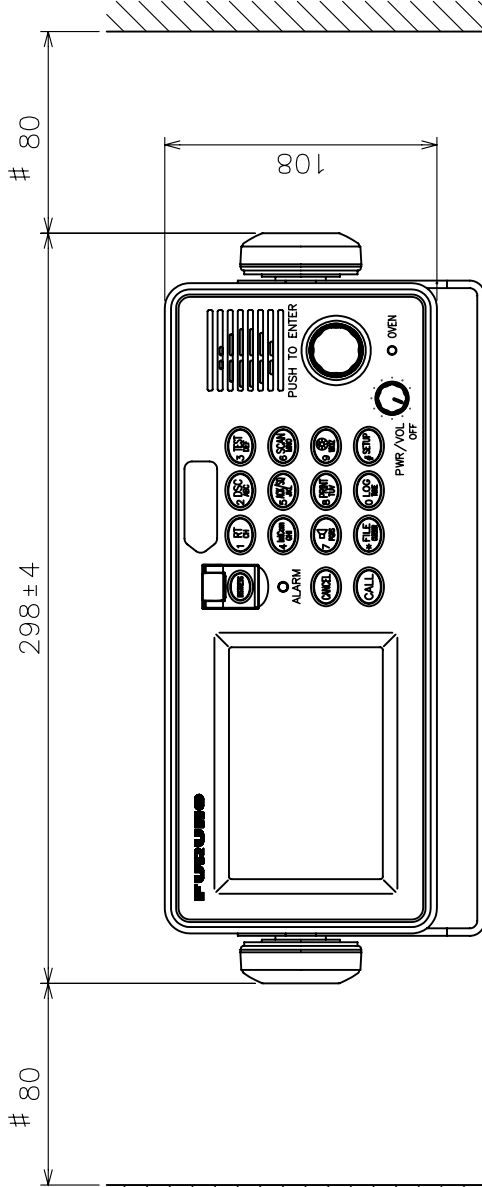
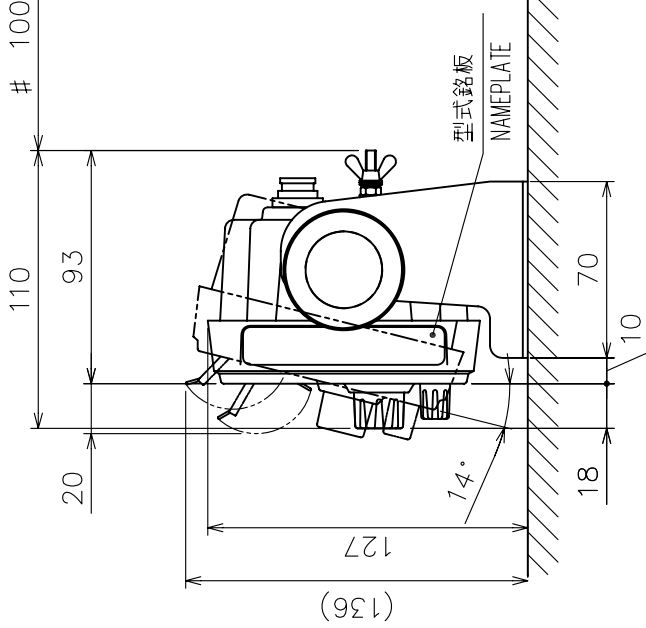
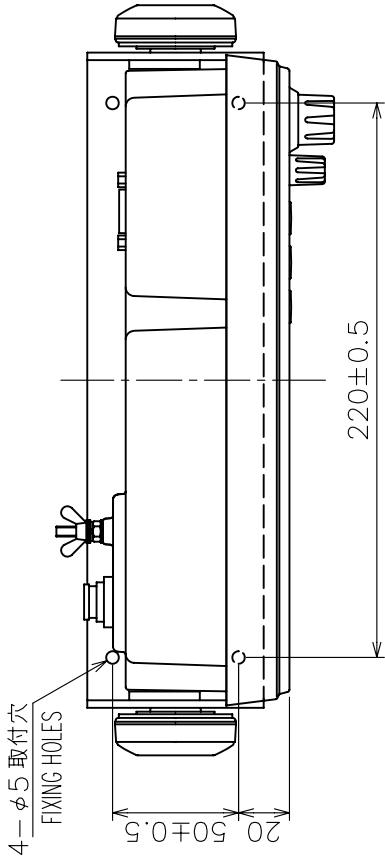
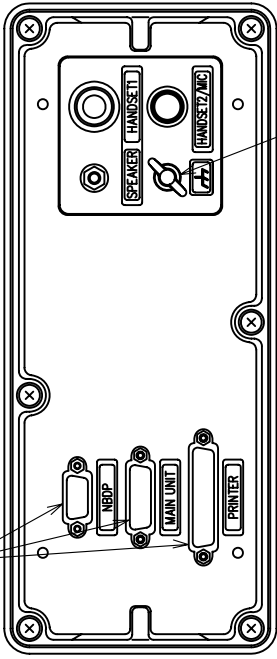

- 注 記 1) # 印寸法は最小サービス空間寸法とする。
 2) 指定外の寸法公差は表 1 による。
 3) 取付用ネジは + トラスタップピンネジ 4 x 16 を使用のこと。
- NOTE 1. # MINIMUM SERVICE CLEARANCE.
 2. TABLE 1 INDICATES TOLERANCE OF DIMENSIONS WHICH IS NOT SPECIFIED.
 3. USE SELF-TAPPING SCREWS 4x16 FOR FIXING THE UNIT.

DRAWN Sep. 28, '06 E. MIYOSHI	TITLE FS-2571C
CHECKED TAKAHASHI, T	名称 操作部 (卓上装備)
APPROVED Y. Hatai	外寸図
SCALE 1/3 MASS 1.6 kg	NAME CONTROL UNIT (TABLETOP MOUNT)
DWG.No. C5656-G01-A	REF.No. 05-094-100G-3

表 1 TABLE1

寸法区分 (mm) DIMENSIONS	公差 (mm) TOLERANCE
L ≤ 50	± 1.5
50 < L ≤ 100	± 2.5
100 < L ≤ 500	± 3

信号、電源コネクタ
SIGNAL, POWER CABLE CONNECTOR

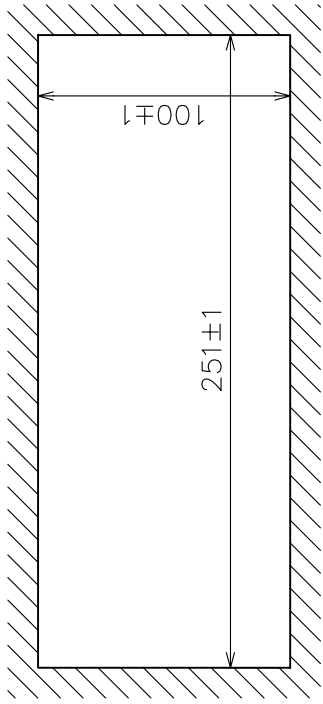

取付穴寸法図(参考図)

CUTOUT DIMENSIONS

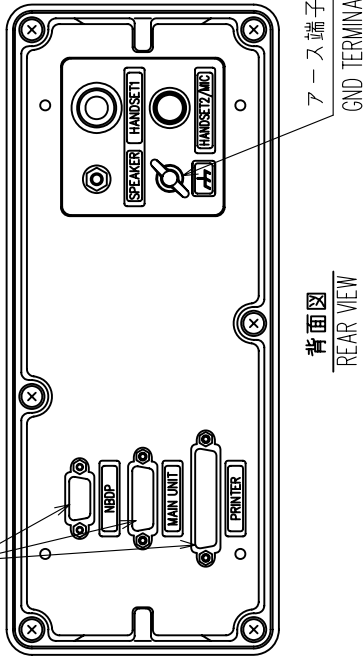
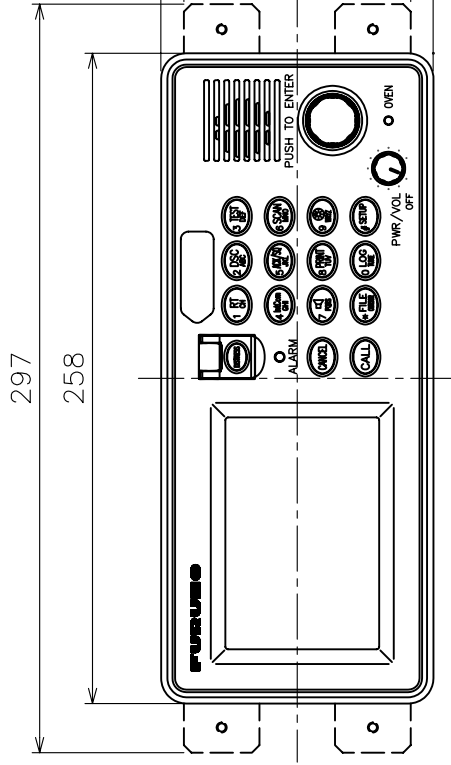

背面図
REAR VIEW

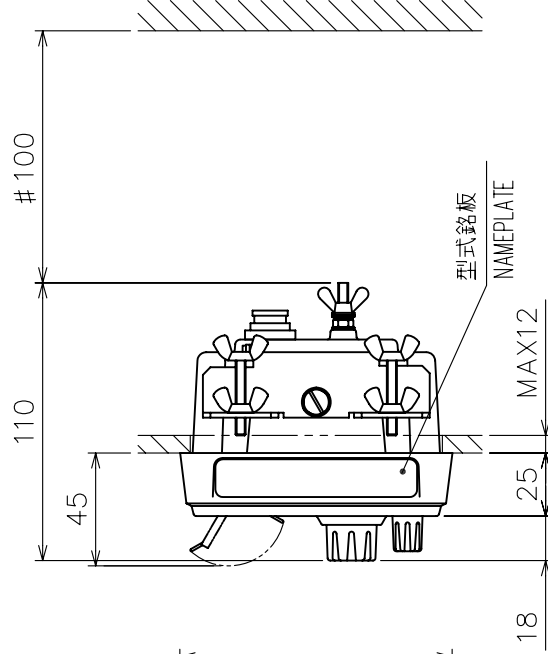

- 注記 1) #印寸法は最小サービスペース寸法とする。
2) 指定外の寸法公差は表1による。
- NOTE 1. # MINIMUM SERVICE CLEARANCE.
2. TABLE 1 INDICATES TOLERANCE OF DIMENSIONS WHICH IS NOT SPECIFIED.

DRAWN	Sep. 28, '06	E. MIYOSHI	TITLE	FS-2571C
CHECKED		TAKAHASHI, T	名称	操作部 (埋込装置)
APPROVED		Y. Hatai	外寸図	
SCALE	1/3	MASS 1.5 kg	NAME	CONTROL UNIT (FLUSH MOUNT)
DWG.No.	C5656-G02-A	REF.No.	05-094-110G-3	OUTLINE DRAWING

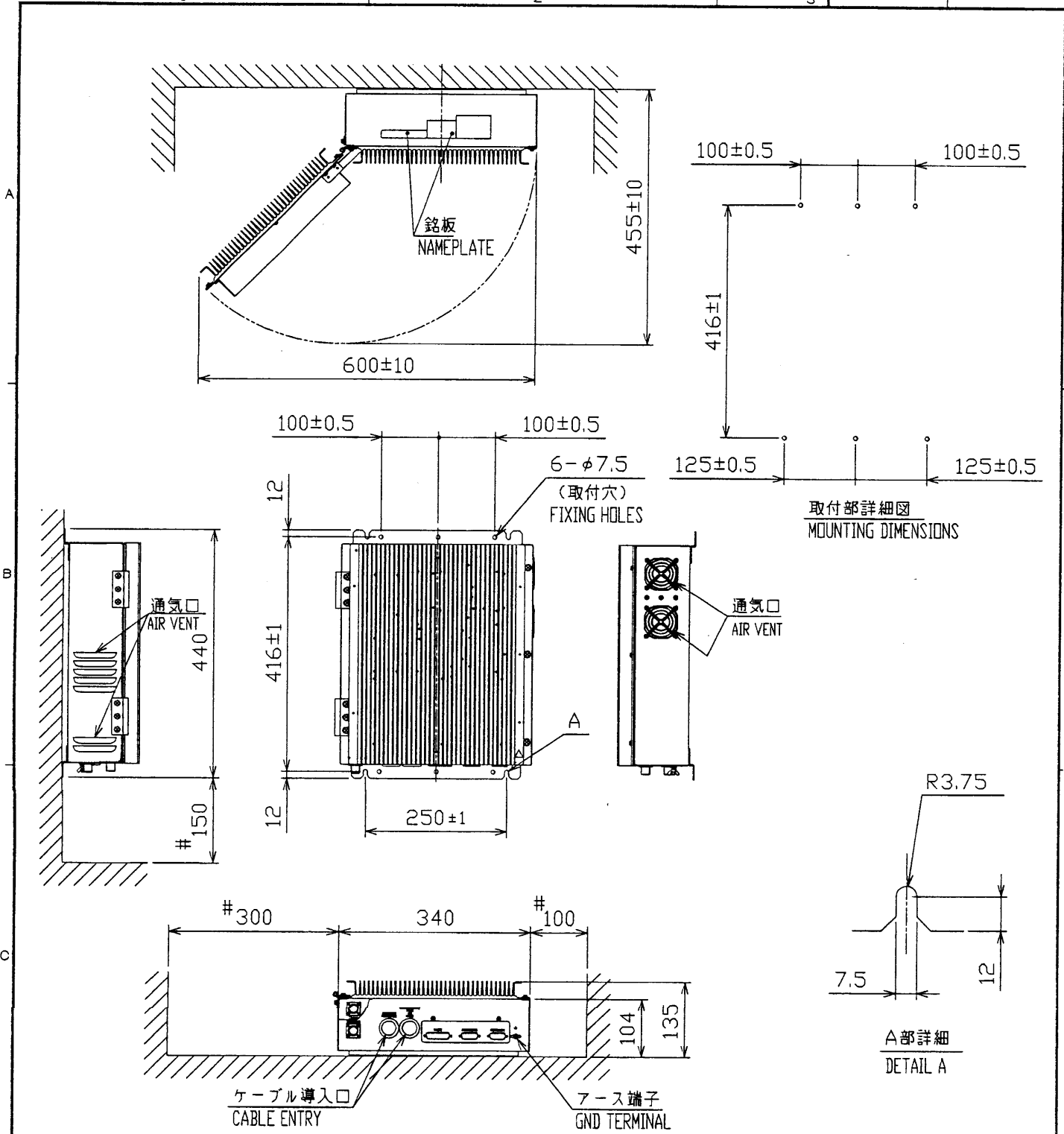

- 注 記 1) #印寸法は最小サービス空周寸法とする。
 2) 指定外の寸法公差は表1による。
 3) 取付用ネジは+トラスタッピンネジ6×20を使用のこと。

- NOTE 1. # RECOMMENDED SERVICE CLEARANCE.
 2. TABLE 1 INDICATES TOLERANCE OF DIMENSIONS.
 3. USE TAPPING SCREWS 6x20 FOR FIXING THE UNIT.

寸法区分 (mm) DIMENSION	公差 (mm) TOLERANCE
$L \leq 50$	± 1.5
$50 < L \leq 100$	± 2.5
$100 < L \leq 500$	± 3

表 1 TABLE 1

DRAWN Aug. 22 '02 T.YAMASAKI	TITLE FS-1570T
CHECKED Aug. 22 '02 Y.K.	名称 送受信部
APPROVED Aug. 22 '02 Y.K.	外寸図
SCALE 1/10 MASS 1 $\pm 10\%$ kg	NAME TRANSCEIVER UNIT
DWG.No. C5636-G03-B	05-089-200G-6 OUTLINE DRAWING

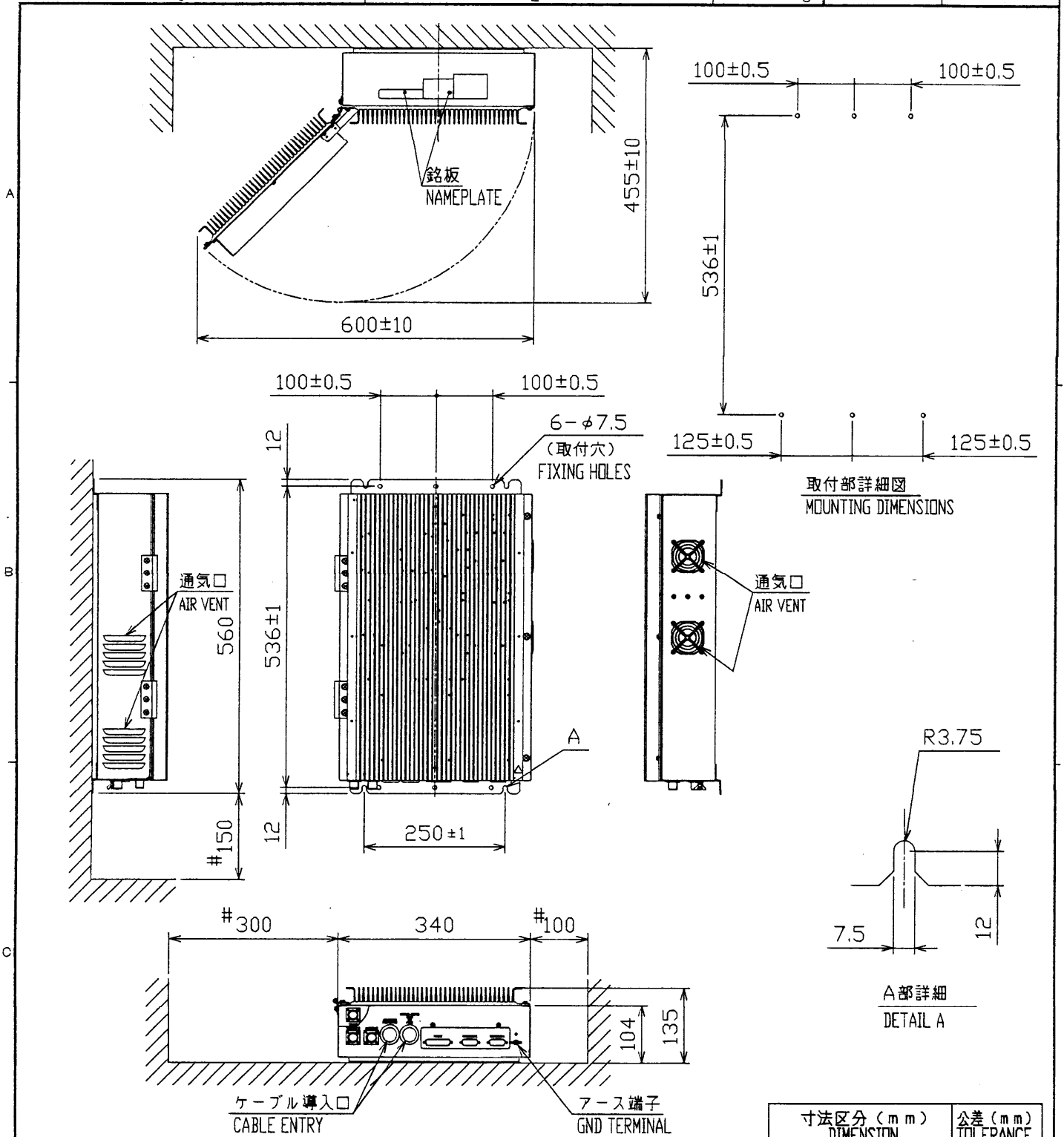

- 注記 1) #印寸法は最小サービス空間寸法とする。
 2) 指定外の寸法公差は表1による。
 3) 取付用ネジは+トラスタッピンネジ 6×20 を使用のこと。

寸法区分 (mm) DIMENSION	公差 (mm) TOLERANCE
$L \leq 50$	± 1.5
$50 < L \leq 100$	± 2.5
$100 < L \leq 500$	± 3
$500 < L \leq 1000$	± 4

- NOTE 1. # RECOMMENDED SERVICE CLEARANCE.
 2. TABLE 1 INDICATES TOLERANCE OF DIMENSIONS.
 3. USE TAPPING SCREWS 6×20 FOR FIXING THE UNIT.

表1 TABLE 1

DRAWN Aug. 22 '02 T. YAMASAKI	TITLE FS-2570T
CHECKED Aug. 22 '02 Y. K.	名称 送受信部
APPROVED Sep. 22 '02 Y. K.	外寸図
SCALE 1/10 MASS $\pm 10\%$ 15 kg	NAME TRANSCIEVER UNIT
DWG.No. C5637-G01-B	05-089-300G-6 OUTLINE DRAWING

表 1 TABLE 1

寸法区分 (mm) DIMENSIONS	公差 (mm) TOLERANCE
L ≤ 50	± 1.5
50 < L ≤ 100	± 2.5
100 < L ≤ 500	± 3

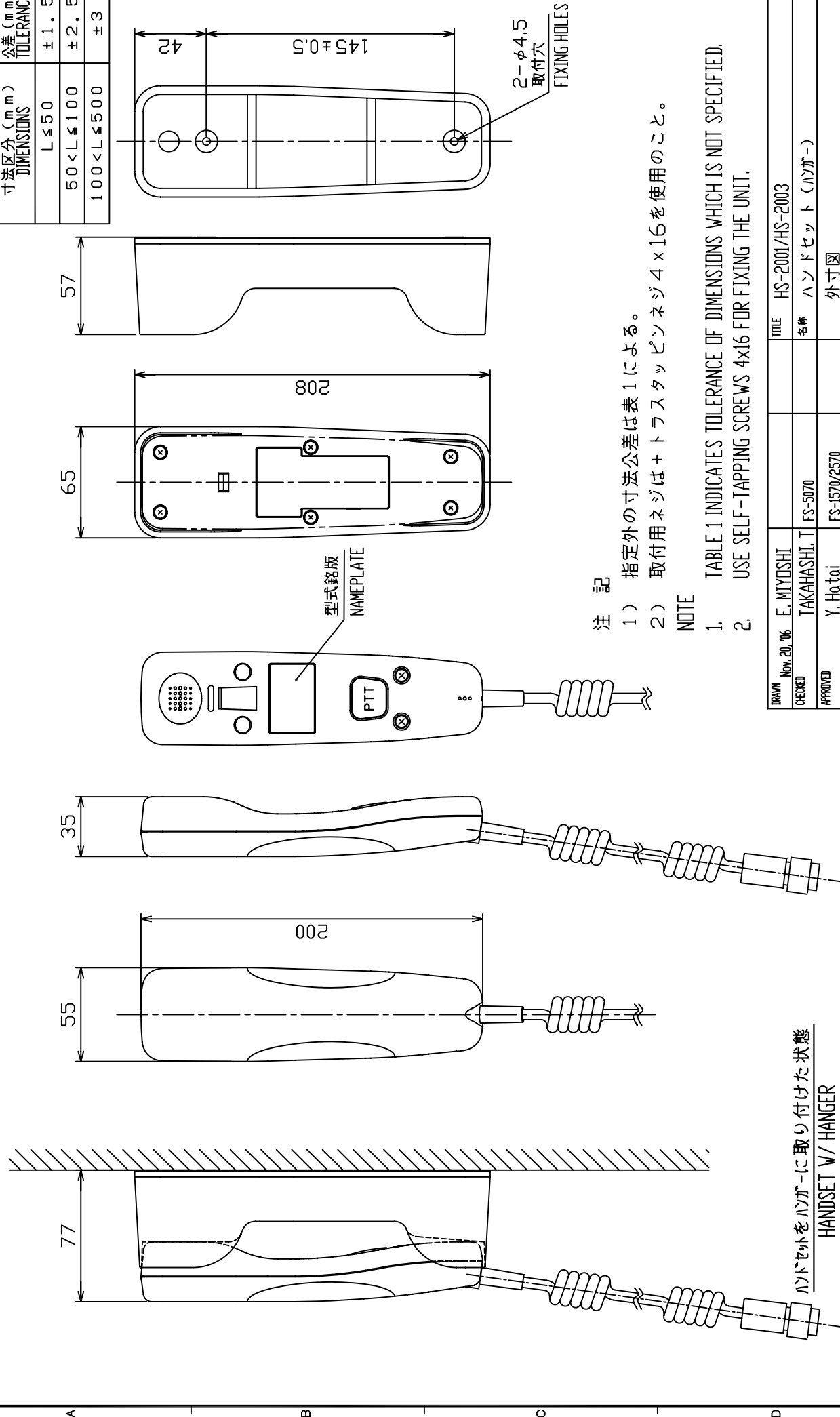

注 記

- 1) 指定外の寸法公差は表 1 による。
- 2) 取付用ネジは + トラスタップピンネジ 4 × 16 を使用のこと。

NOTE

- 1. TABLE 1 INDICATES TOLERANCE OF DIMENSIONS WHICH IS NOT SPECIFIED.
- 2. USE SELF-TAPPING SCREWS 4x16 FOR FIXING THE UNIT.

DRAWN	Nov. 20, '06	E. MIYOSHI	TITLE	HS-2001/HS-2003
CHECKED		TAKAHASHI, T	名称	ハンドセット (ハンガ-)
APPROVED		Y. Hattai	外寸図	
SCALE	1/3	質量 0.54 ± 10% 質量はハンガ-、フ-、ハンガ-を含む。 MASS W/ CABLE AND HANGER.	NAME	HANDSET / HANGER
DMG No.		CS636-G04-E		OUTLINE DRAWING

ハンドセットをハンガ-に取り付けた状態
HANDSET W/ HANGER

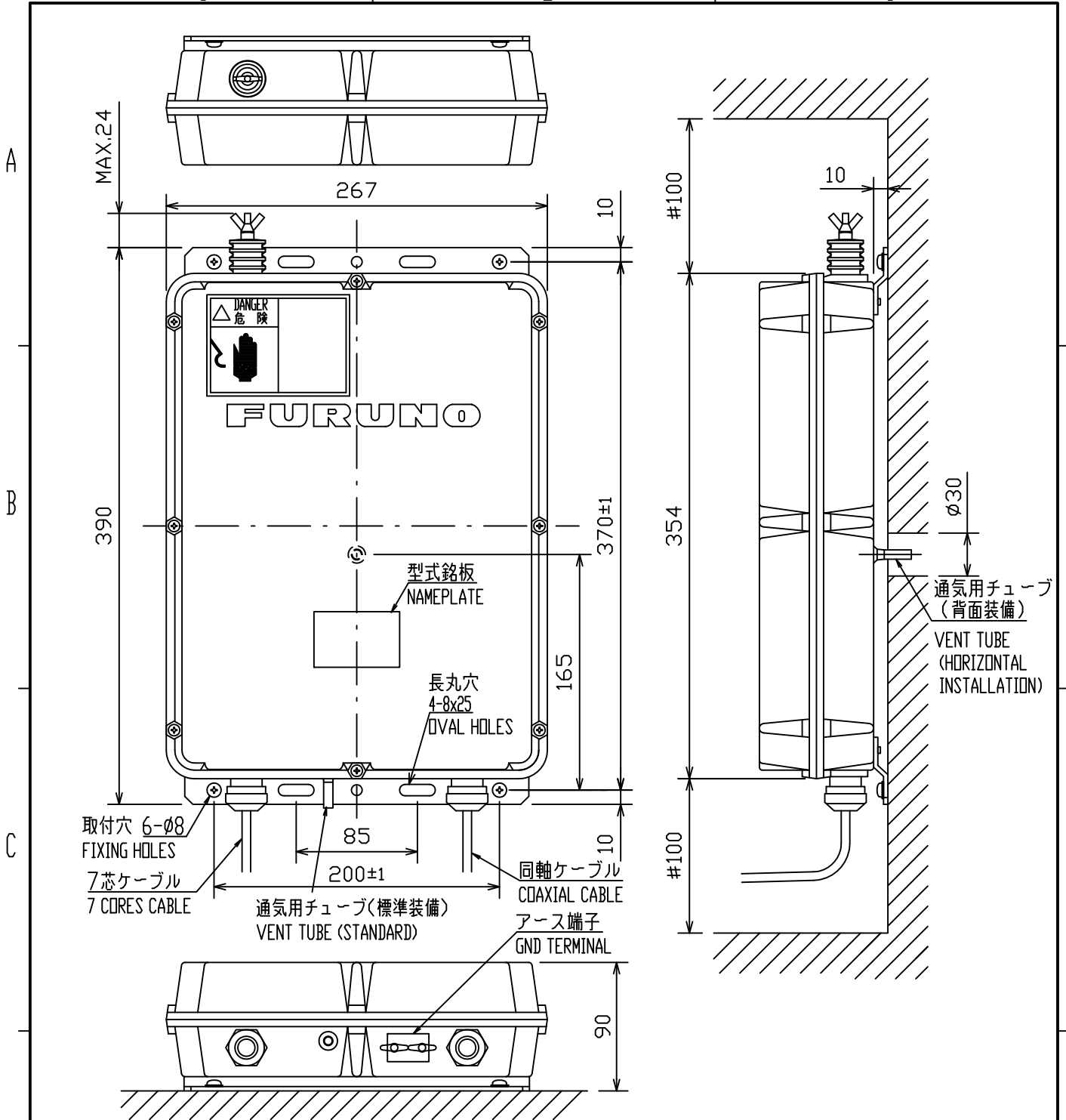

注記

- 1) 指定なき寸法公差は表1による。
- 2) # : 最小サービス空間寸法。
- 3) 通気用チューブは側面 (標準装備) または背面のどちらかに取り付けてください。

NOTE

1. TABLE 1 INDICATES TOLERANCE OF DIMENSIONS WHICH IS NOT SPECIFIED.
2. #: MINIMUM SERVICE CLEARANCE.
3. VENT TUBE SHOULD BE MOUNTED ON EITHER BOTTOM (FACTORY MOUNT) OR REAR OF THE COUPLER, DEPENDING ON INSTALLATION METHODS.

表1 TABLE 1

寸法区分(mm) DIMENSION	公差(mm) TOLERANCE
0 < L ≤ 50	±1.5
50 < L ≤ 100	±2.5
100 < L ≤ 500	±3

DRAWN 1/Dec/2010 T.YAMASAKI		TITLE AT-1560-15/25-AAS/HAAS
CHECKED 2/Dec/2010 T.TAKAHASHI		名称 アンテナカプラ
APPROVED 2/Dec/2010 Y.NISHIYAMA	FS-1570 ser. FS-1562/2550, FS-15/75	外寸図
SCALE 1/4	MASS 3.2 ±10% kg	NAME ANTENNA COUPLER
DWG.No. C5574-G01-F	REF. No.	OUTLINE DRAWING

表1 TABLE 1

寸法区分 (mm) DIMENSION	公差 (mm) TOLERANCE
$L \leq 50$	± 1.5
$50 < L \leq 100$	± 2.5
$100 < L \leq 500$	± 3

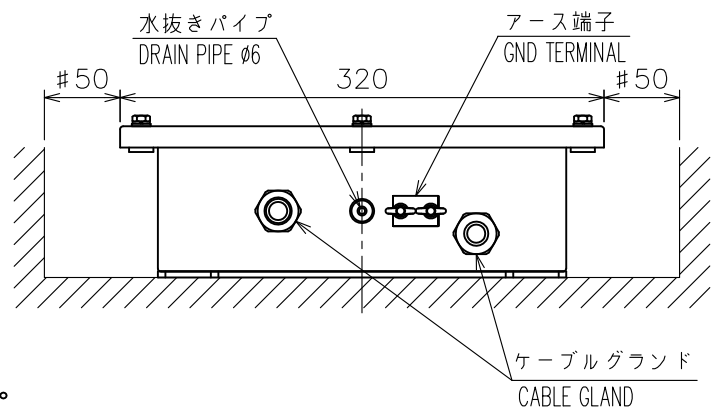
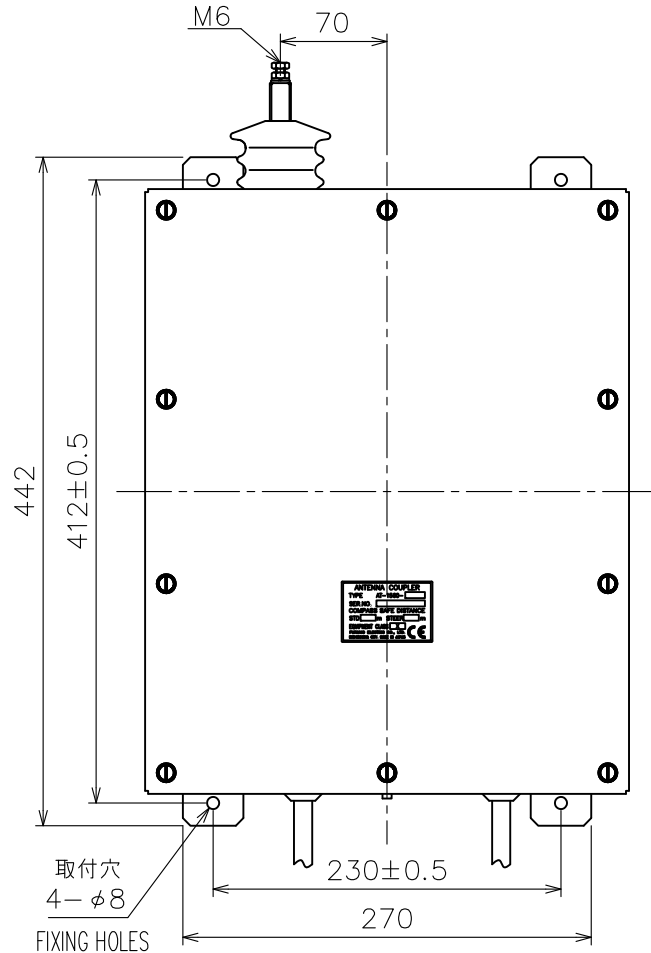
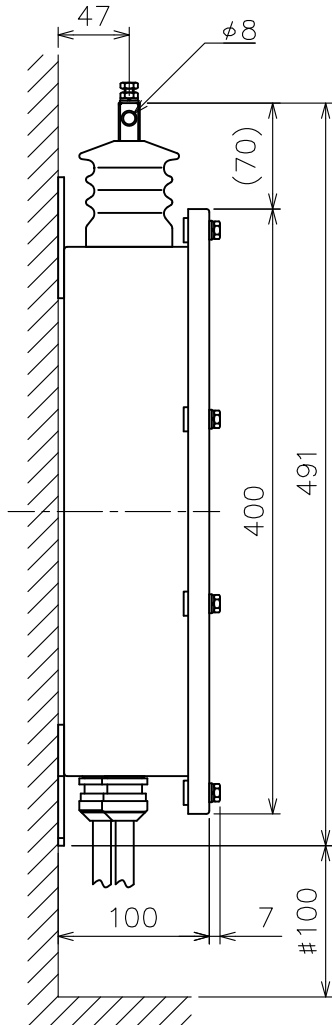
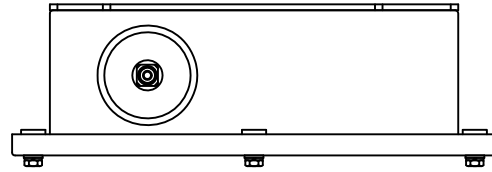

注記 1) 指定外の寸法公差は表1による。
2) #印寸法は最小サービス空間寸法とする。

NOTE 1. TABLE 1 INDICATES TOLERANCE OF DIMENSIONS WHICH IS NOT SPECIFIED.
2. #: MINIMUM SERVICE CLEARANCE.

DRAWN	1/Dec/2010 T.YAMASAKI	TITLE	AT-1560-15/25-SUS/HSUS
CHECKED	2/Dec/2010 T.TAKAHASHI	名称	アンテナカプラ
APPROVED	2/Dec/2010 Y.NISHIYAMA	FS-1570 ser. FS-1562/2550, FS-15/75	外寸図
SCALE	1/5	MASS	8.8 $\pm 10\%$ kg
DWG. No.	C5572-G03-C	REF. No.	05-029-030G-3
		NAME	ANTENNA COUPLER OUTLINE DRAWING

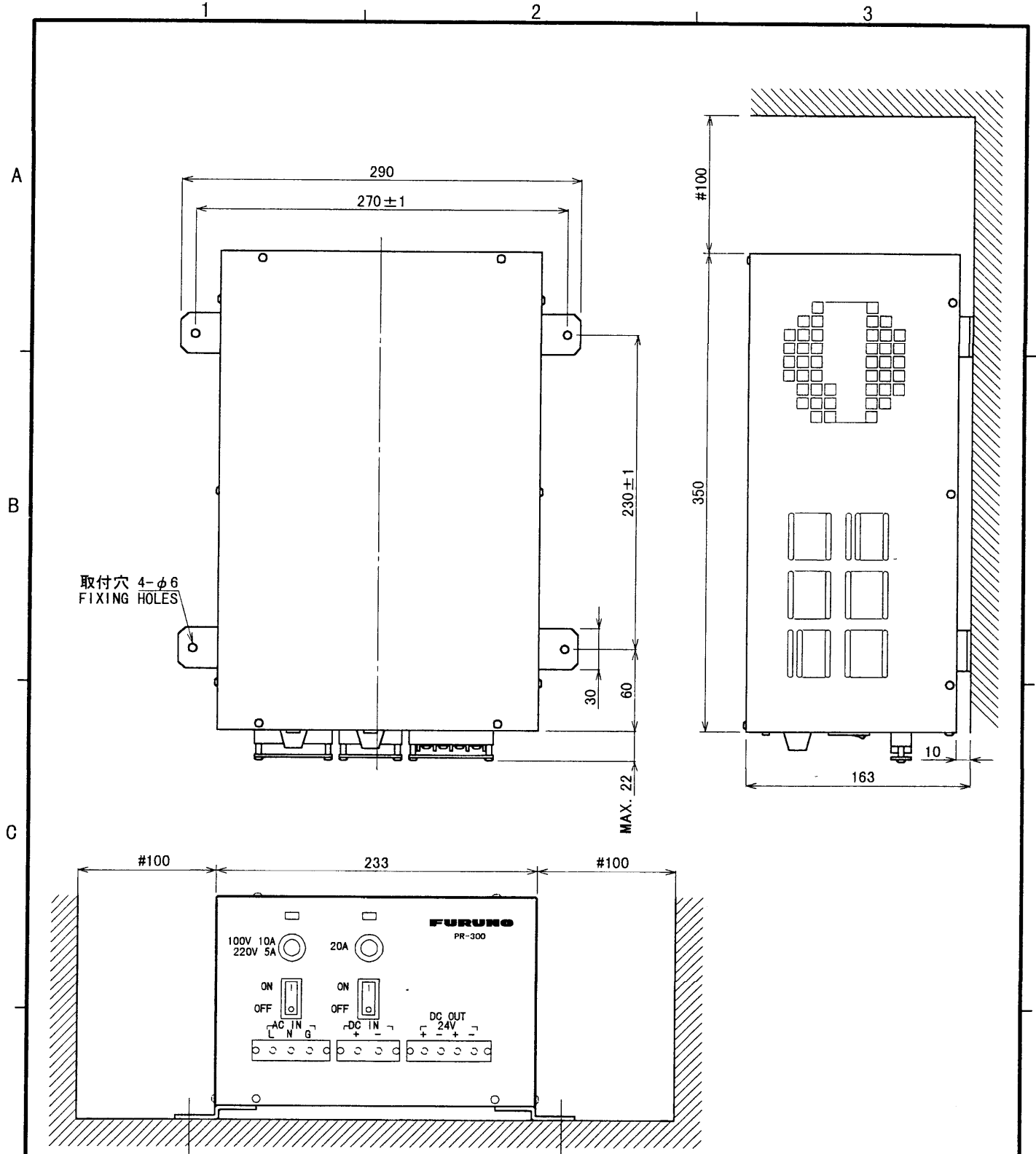

注記
 1) #: 推奨する最小サービス空間寸法。
 2) 指定なき寸法公差は表 1 による。

NOTE:
 1. #: RECOMMENDED SERVICE CLEARANCE.
 2. TABLE 1 INDICATES TOLERANCE OF DIMENSIONS.

表 1 TABLE 1

寸法範囲 (mm) DIMENSION	公差 (mm) TOLERANCE
0 < L ≤ 50	±1.5 mm
50 < L ≤ 100	±2.5 mm
100 < L ≤ 500	±3 mm

DRAWN <i>June 19 '00 T. Yamasaki</i>	TITLE PR-300
CHECKED <i>June 19 '00 Y. Kimura</i>	名称 AC-DC電源ユニット
APPROVED <i>June 19 '00 T. Yamasaki</i>	外寸図
SCALE 1/4	NAME AC-DC POWER SUPPLY UNIT
MASS ±10% 14.5 kg	OUTLINE DRAWING
DWG. No. C5003-G02- D	

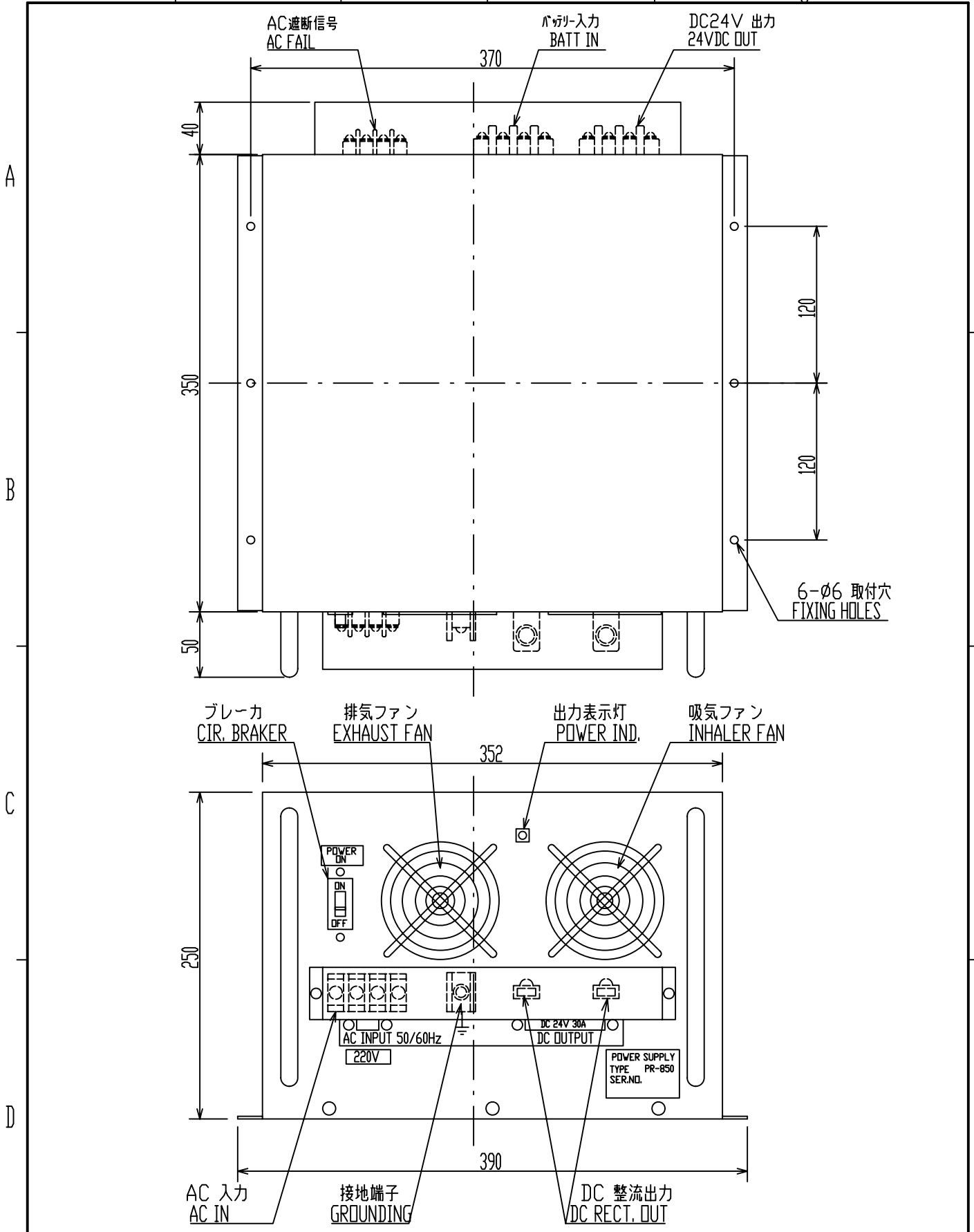

DRAWN	Nov. 25, '06	E. MIYOSHI	TITLE	PR-850A
CHECKED		TAKAHASHI.T	名称	AC-DC電源ユニット
APPROVED		Y. Hatai		外寸図
SCALE	1/4	MASS 35 ±10% kg	NAME	AC-DC POWER SUPPLY UNIT
DWG.No.	C5519-G11-G	REF.No.		OUTLINE DRAWING



表 1 TABLE 1

寸法区分 (mm) DIMENSIONS	公差 (mm) TOLERANCE
0 < L ≤ 50	± 1.5
50 < L ≤ 100	± 2.5
100 < L ≤ 500	± 3

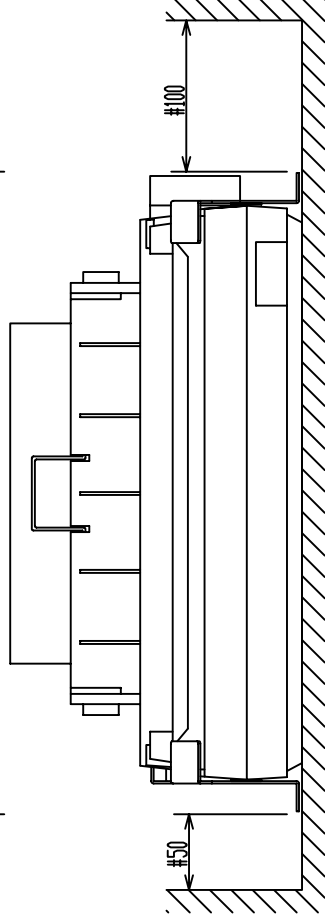
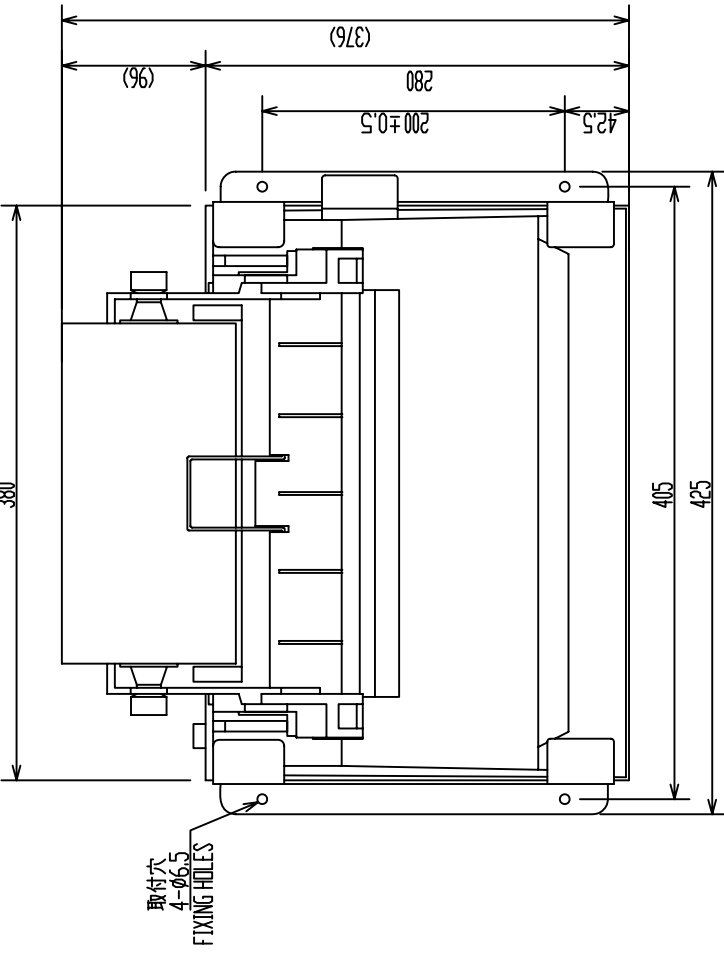
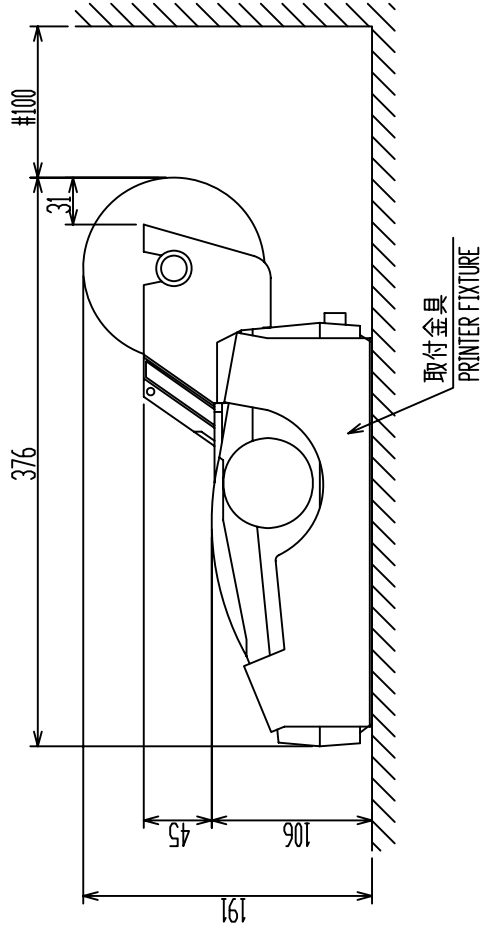

- 注 記
- 1) 印寸法は最小サービス空間寸法とする。
 - 2) 指定外の寸法公差は表 1 による。
 - 3) 取付用ネジは M6 ボルトまたはコーチボルト呼び径φ を使用のこと。
- NOTE
1. # MINIMUM SERVICE CLEARANCE.
 2. TABLE 1 INDICATES TOLERANCE OF DIMENSIONS WHICH IS NOT SPECIFIED.
 3. USE M6 BOLTS OR COACH SCREWS φ6 FOR FIXING THE UNIT.

DRAWN Nov. 27, '96	E. MIYOSHI	TITLE PP-510
CHECKED	TAKAHASHI, I.	名称 プリンタ
APPROVED	Y. Hatai	外寸図
SCALE 1/5	MASS ±10% 3.8 kg	NAME PRINTER
DWG.No.	C5589-G08-K	REF.No.
	16-007-660G-2	OUTLINE DRAWING

A

B

C

D

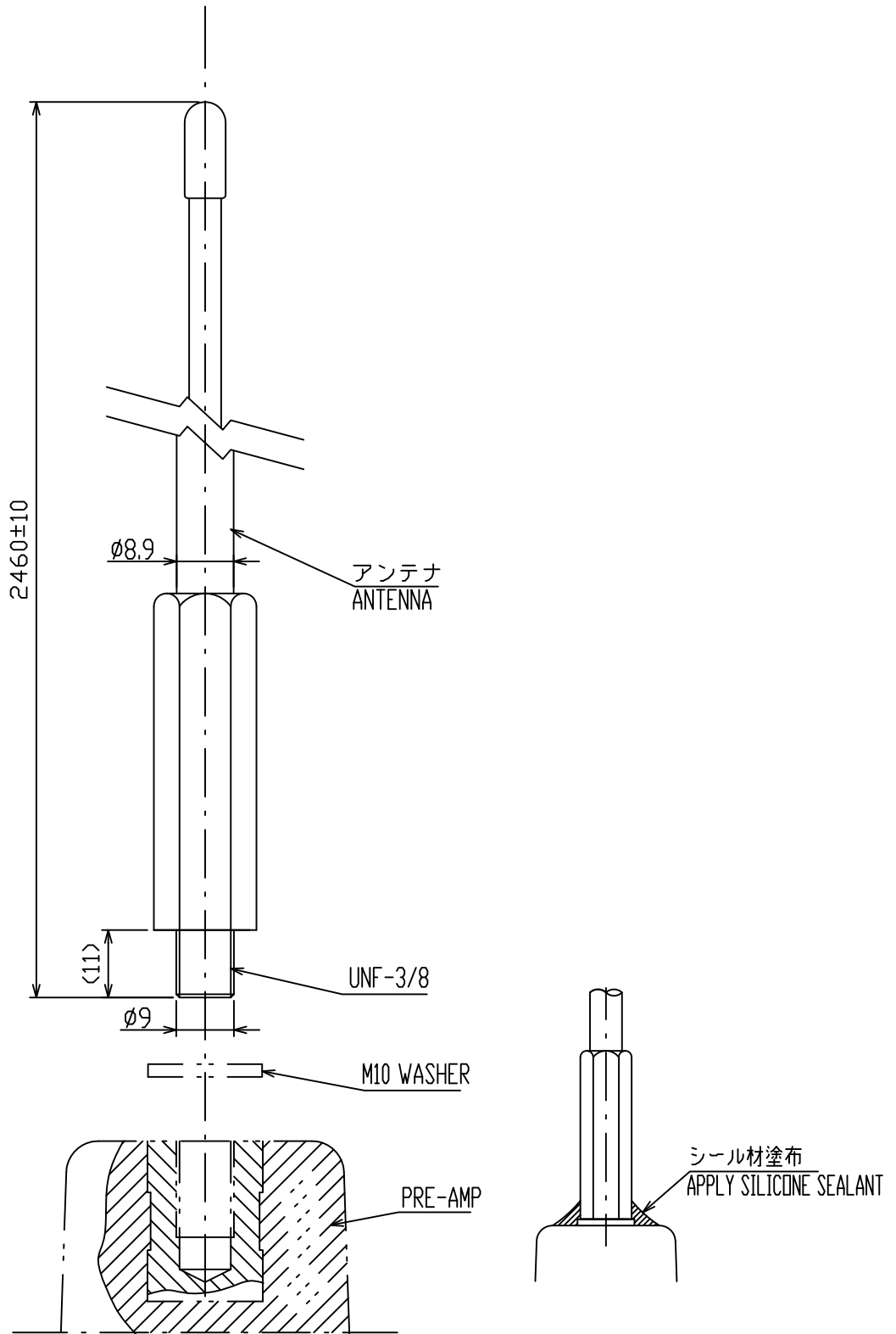

DRAWN	17/Jun/09	T.YAMASAKI	TITLE	04S4176
CHECKED	17/Jun/09	T.TAKENO	名称	2.6m ホイップアンテナ
APPROVED	26/Jun/09	R. Esumi		外寸図
SCALE	1/1	MASS 0.5 ±10% kg	NAME	2.6m WHIP ANTENNA
DWG.No.	C4002-018-J		REF.No.	OUTLINE DRAWING

表 1 TABLE 1

寸法範囲 (mm) DIMENSIONS	公差(mm) TOLERANCE
$L \leq 50$	± 1.5
$50 < L \leq 100$	± 2.5
$100 < L \leq 500$	± 3

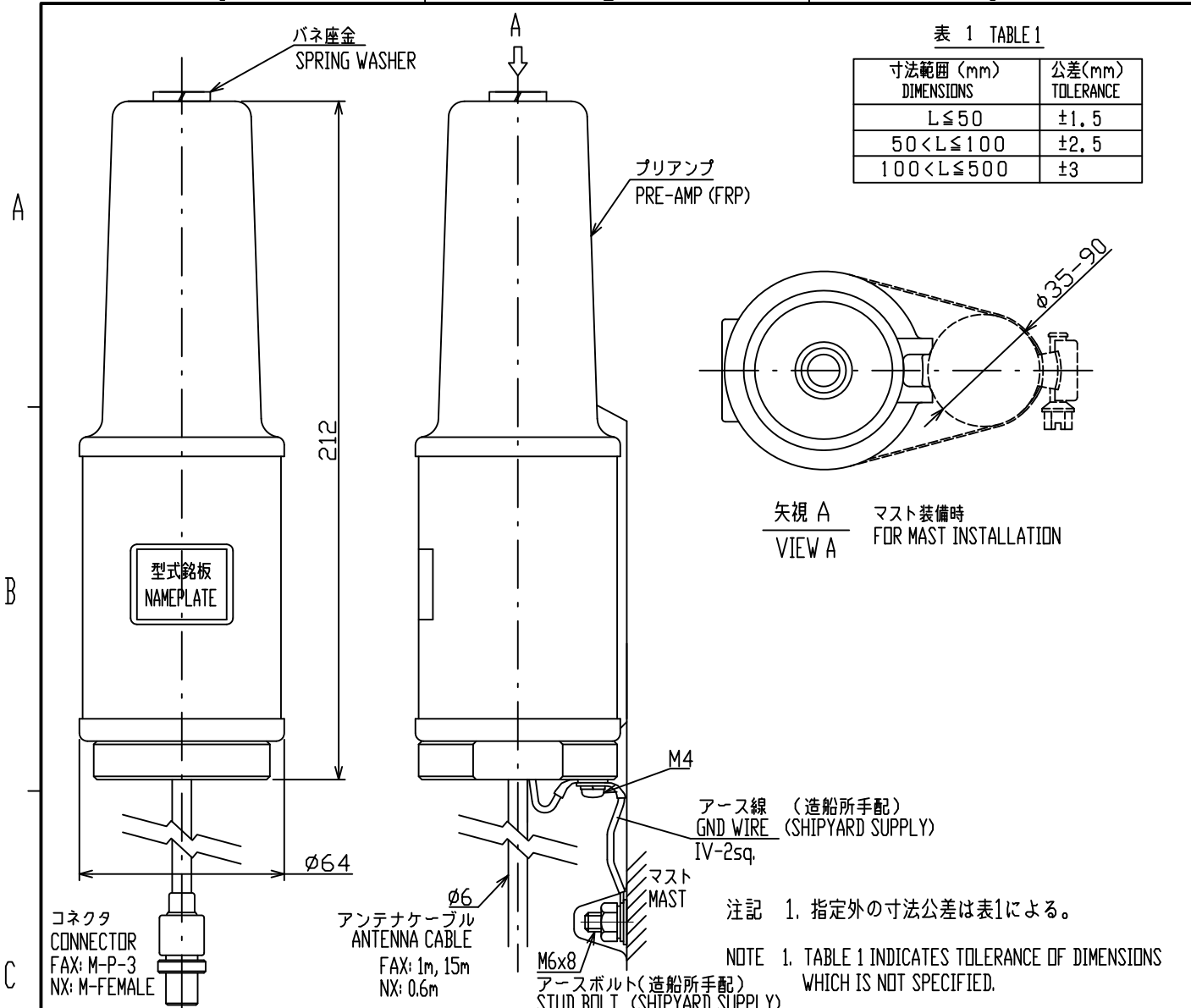

マストへの取付
MAST MOUNTING

パイプ装備
FIXING TO PIPE

ホイップアンテナの場合
FOR WHIP ANTENNA

マスト装備
FIXING TO MAST

アンテナワイヤの場合
FOR ANTENNA WIRE

アンテナ取付ネジ
COUPLING SCREW

アンテナワイヤ
ANTENNA WIRE

アンテナワイヤ取付金具
ANTENNA WIRE FIXTURE

ウィット細目ネジ
WHITWORTH FINE
SCREW THREADS
(W25-14)

テープを巻く
WIND TAPE

シール剤で固定
APPLY SILICONE SEALANT

ボルト
M6x8 BOLT

パーカークランプ
HOSE CLAMP

ボルト
M6x8 BOLT

ケーブルタイ (LOCAL SUPPLY)
ケーブル固定バンド (現地手配)

パイプ (造船所手配) Ø27.2
PIPE (SHIPYARD SUPPLY)

アンテナケーブル
ANTENNA CABLE

注記 装備前にパイプをプリアンプにねじ込むこと。
NOTE FASTEN PIPE TO ANTENNA BEFORE INSTALLATION.

DRAWN 24/Mar/2011 J.YAMASAKI

CHECKED 24/Mar/2011 H.MAKI

APPROVED 25/Mar/2011 Y.NISHIYAMA

SCALE 1/2 MASS 0.6 ±10% kg

DWG.No. C6244-003-P

TITLE FAX-5, NX-5/6

名称 プリアンプ

外寸図

NAME PRE-AMP UNIT

OUTLINE DRAWING

質量はケーブルを含まず。
MASS DOES NOT INCLUDE CABLE.

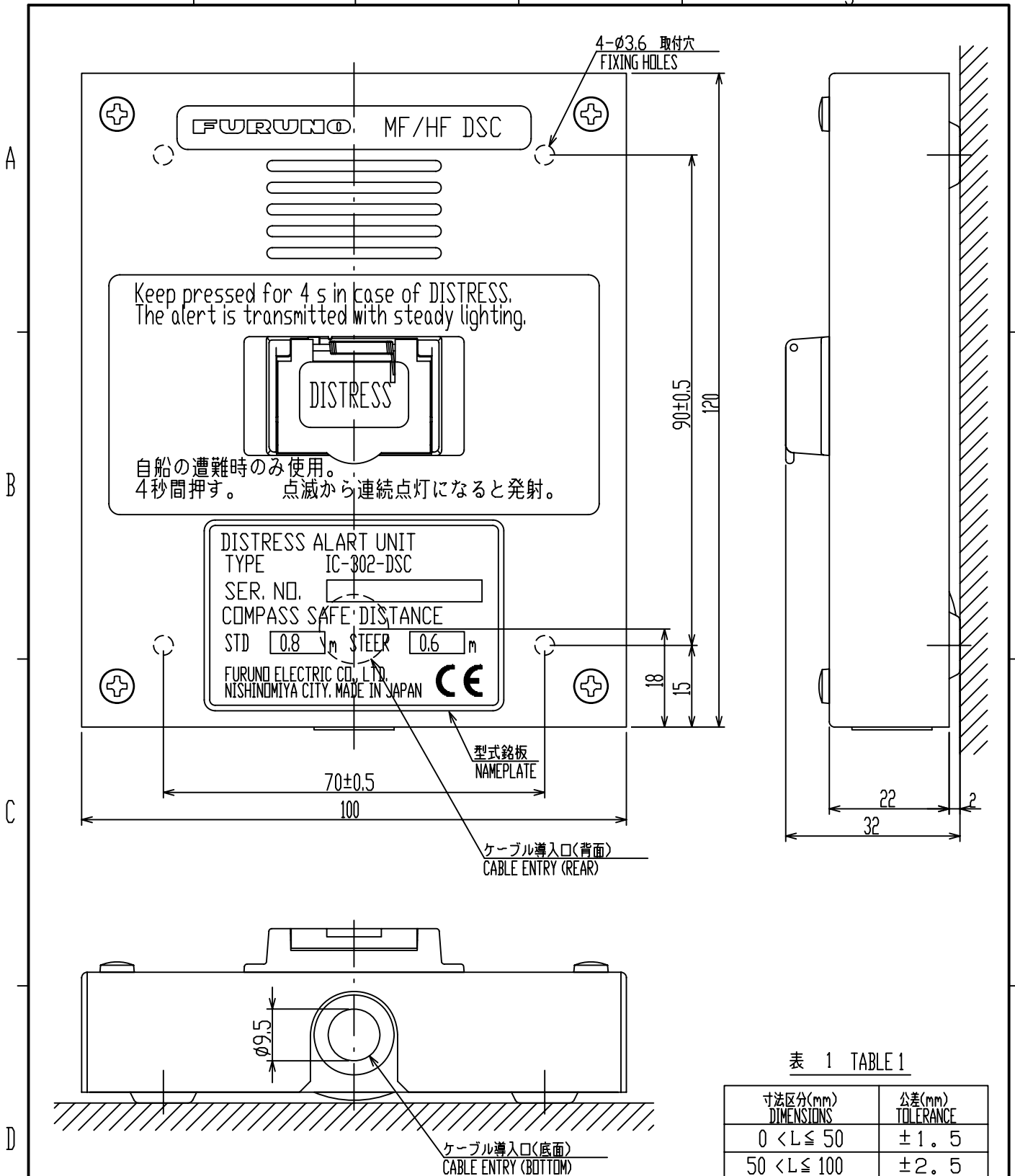

Keep pressed for 4 s in case of DISTRESS.
The alert is transmitted with steady lighting.



自船の遭難時のみ使用。
4秒間押す。点滅から連続点灯になると発射。

DISTRESS ALERT UNIT
TYPE IC-302-DSC
SER. NO.
COMPASS SAFE DISTANCE
STD m STEER m
FURUNO ELECTRIC CO., LTD.
NISHINOMIYA CITY, MADE IN JAPAN

表 1 TABLE 1

寸法区分(mm) DIMENSIONS	公差(mm) TOLERANCE
0 < L ≤ 50	± 1.5
50 < L ≤ 100	± 2.5
100 < L ≤ 500	± 3

注記 1) 指定外寸法公差は表 1 による。

NOTE 1. TABLE 1 INDICATES TOLERANCE OF DIMENSIONS WHICH IS NOT SPECIFIED.

DRAWN Nov. 20, '06 E. MIYOSHI	TITLE IC-302-DSC
CHECKED TAKAHASHI, T	名称 遭難警報発呼器
APPROVED Y. Hatai	外寸図
SCALE 1/1 MASS 0.33 ±10% kg	NAME DISTRESS ALERT UNIT
DWG.No. C5628-G02-C	REF.No. 16-013-3110-G2 OUTLINE DRAWING



表 1 TABLE 1

寸法区分(mm) DIMENSIONS	公差(mm) TOLERANCE
0 < L ≤ 50	± 1.5
50 < L ≤ 100	± 2.5
100 < L ≤ 500	± 3

注記 1) 指定外寸法公差は表 1 による。

NOTE 1. TABLE 1 INDICATES TOLERANCE OF DIMENSIONS WHICH IS NOT SPECIFIED.

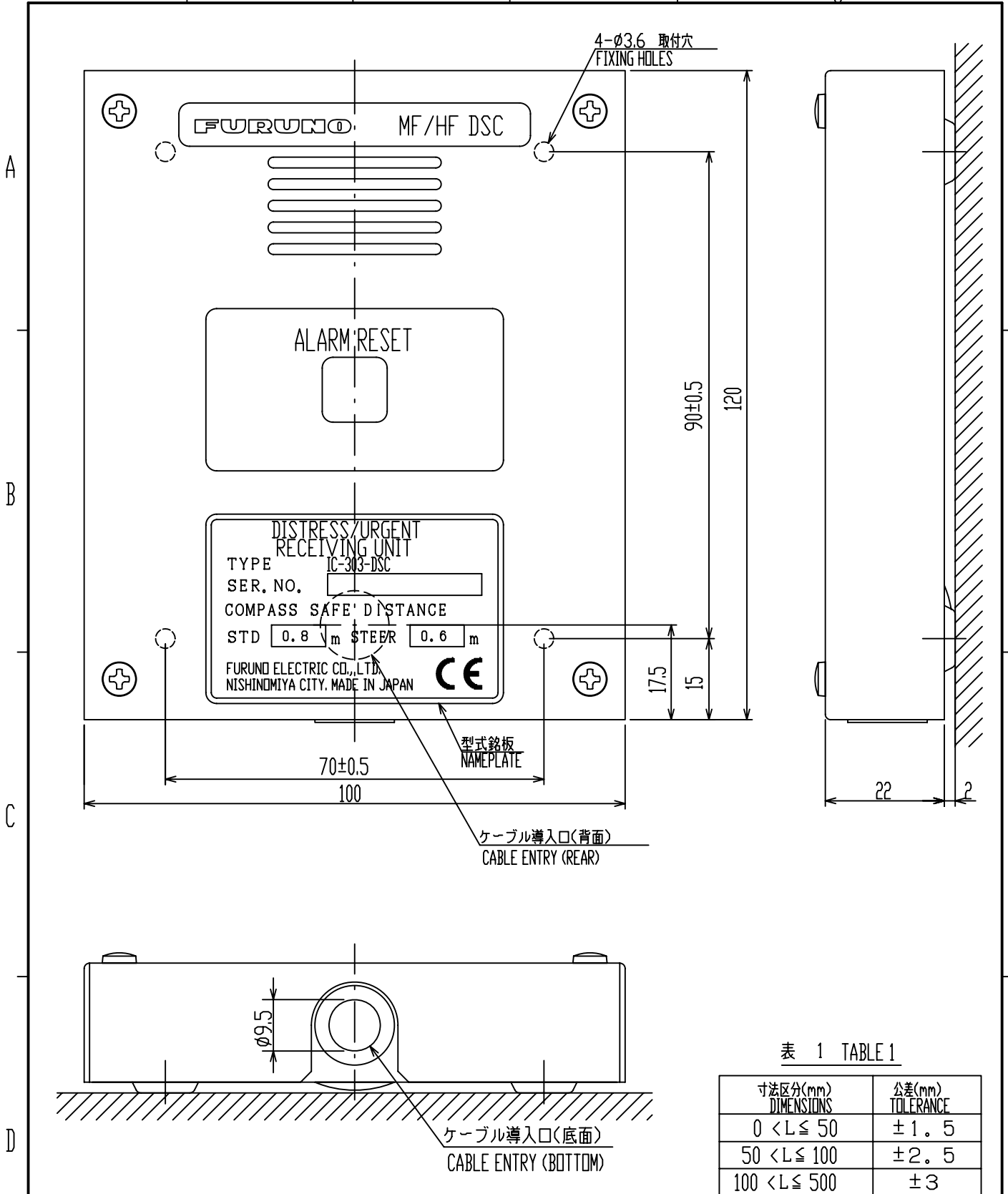
DRAWN Nov. 20, '06 E. MIYOSHI	TITLE IC-303-DSC
CHECKED TAKAHASHI, T	名称 着信指示器 (遭難警報用)
APPROVED Y. Hatai	外寸図
SCALE 1/1 MASS 0.33 ±10% kg	NAME DISTRESS/URGENT RECEIVING UNIT
DWG.No. C5628-G03-C	REF.No. 16-013-3120-G2 OUTLINE DRAWING

表1 TABLE 1

寸法区分(mm) DIMENSIONS	公差(mm) TOLERANCE
0 < L ≤ 50	±1.5
50 < L ≤ 100	±2.5
100 < L ≤ 500	±3

A

B

C

D

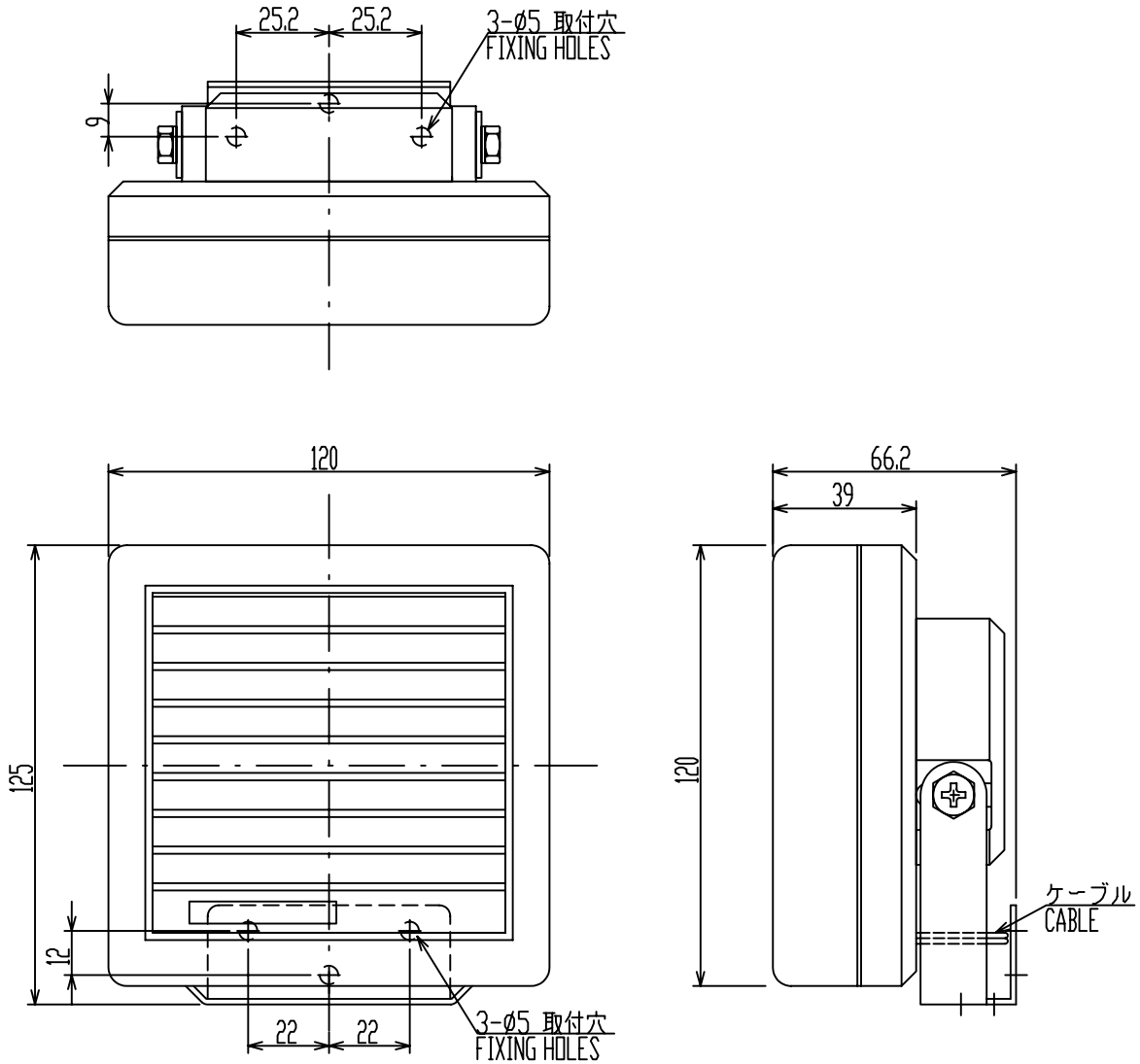

注記 1) 指定外寸法公差は表1による。

NOTE 1. TABLE 1 INDICATES TOLERANCE OF DIMENSIONS WHICH IS NOT SPECIFIED.

DRAWN	Nov. 25, '06	E. MIYOSHI	TITLE	SEM-21Q
CHECKED		TAKAHASHI, T	名称	スピーカ
APPROVED		Y. Hatai		外寸図
SCALE	1/2	MASS 0.54 ±10% kg	質量は2.8mケーブルを含む MASS W/ 2.8m CABLE	NAME
DWG.No.	C5016-G07-C	REF.No.		LOUDSPEAKER
				OUTLINE DRAWING

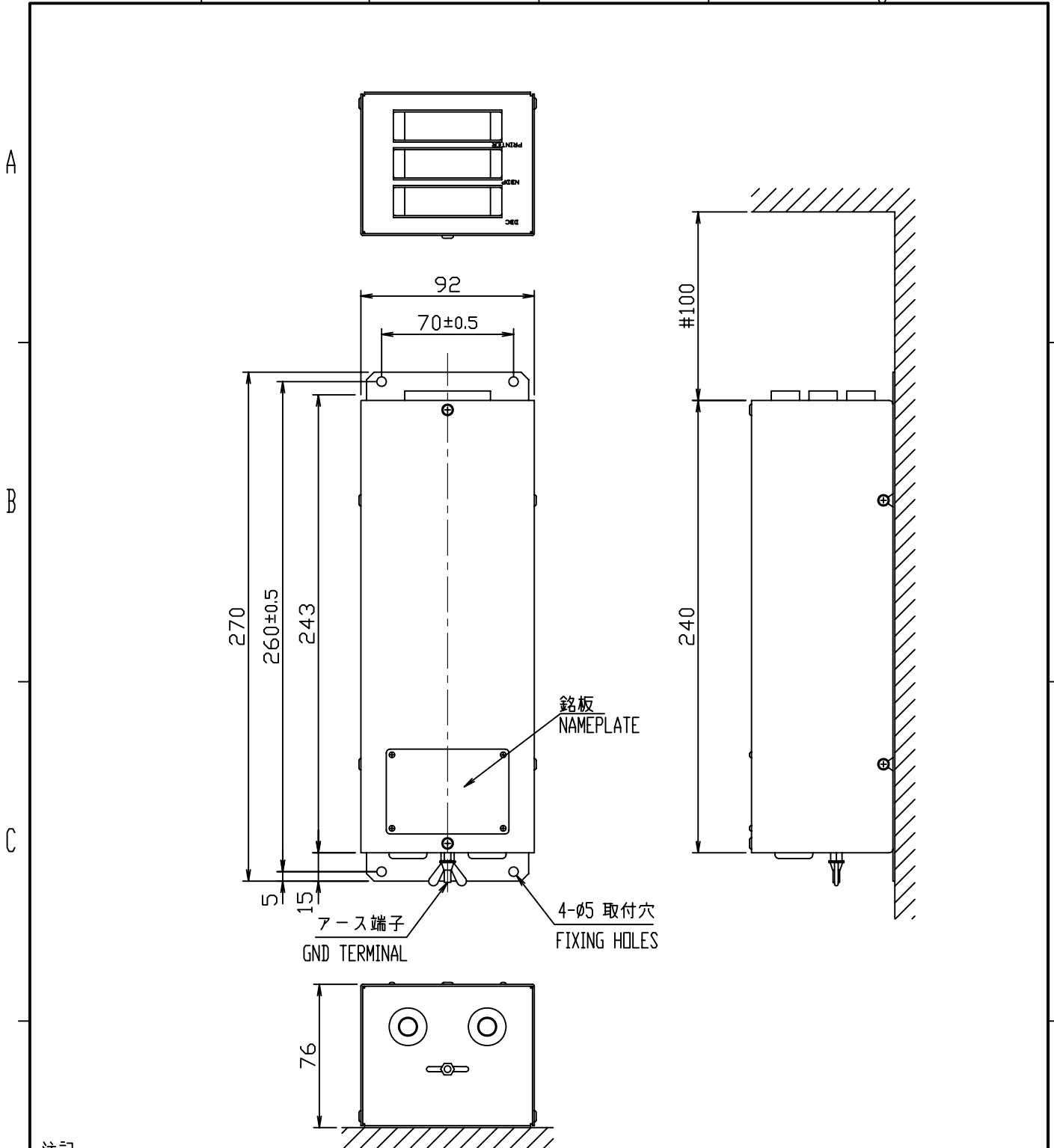

注記

- 1) 指定なき寸法公差は表1による。
- 2) # : 最小サービス空間寸法。

NOTE

- 1. TABLE 1 INDICATES TOLERANCE OF DIMENSIONS WHICH IS NOT SPECIFIED.
- 2. #: MINIMUM SERVICE CLEARANCE.

表1 TABLE 1

寸法区分(mm) DIMENSION	公差(mm) TOLERANCE
0 < L ≤ 50	±1.5
50 < L ≤ 100	±2.5
100 < L ≤ 500	±3

DRAWN Sep. 6 '06 T.YAMASAKI	TITLE IF-8500
CHECKED Sep. 6 '06 T.TAKENO	名称 プリンターインターフェイス
APPROVED Sep. 21 '06 T.Matsuguchi	外寸図
SCALE 1/3	NAME PRINTER INTERFACE
MASS 0.7 ±10% kg	
DWG.No. C5603-G05- C	05-073-2100-G1 OUTLINE DRAWING

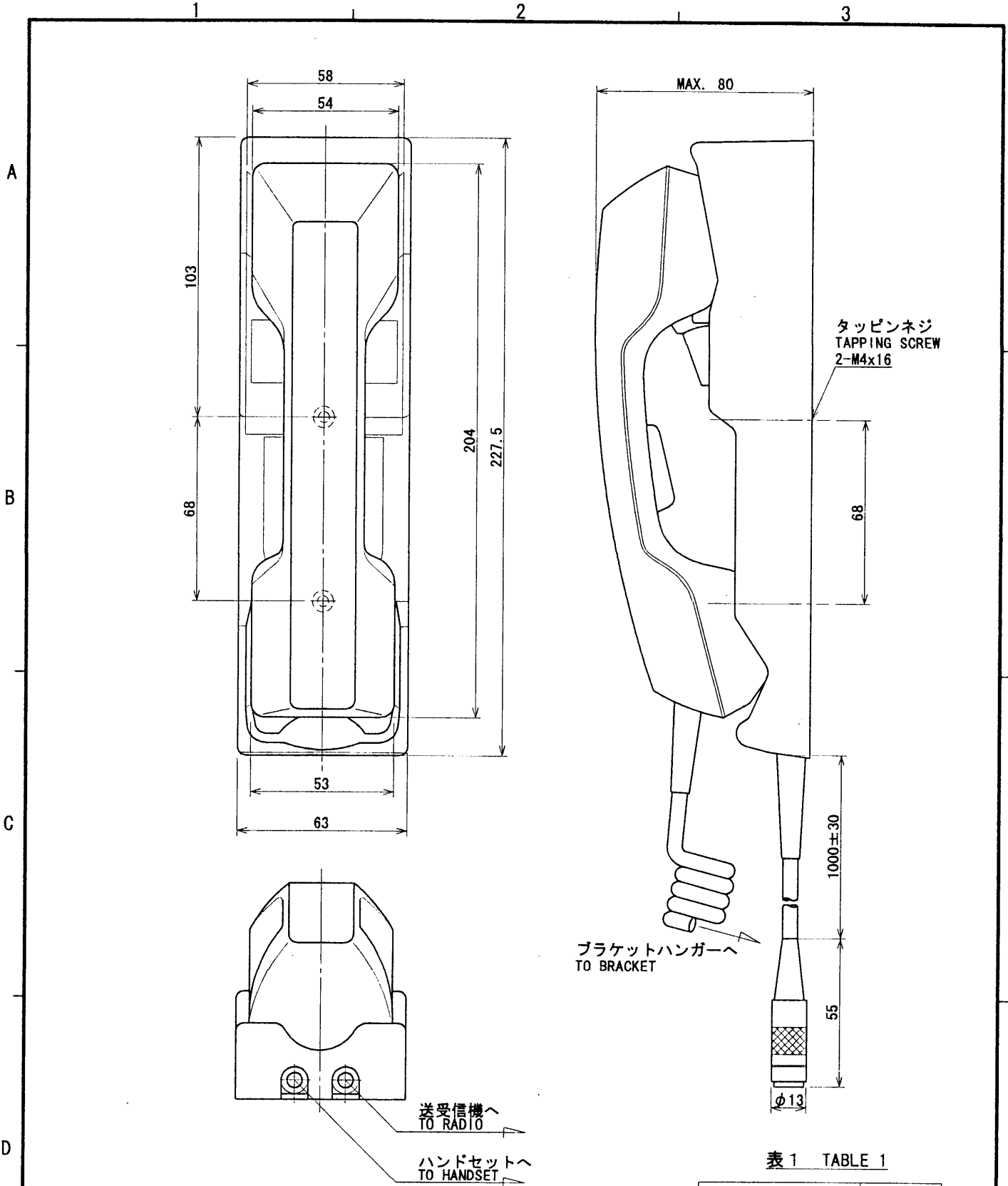

注記
1) 指定なき寸法公差は表1による。

NOTE
1. TABLE 1 INDICATES TOLERANCE OF DIMENSIONS.

表1 TABLE 1

寸法区分 (mm) DIMENSION	公差 (mm) TOLERANCE
0 < L ≤ 50	±1.5
50 < L ≤ 100	±2.5
100 < L ≤ 500	±3

DRAWN Nov 16 '99 T. YAMASAKI	TITLE HSC701K-B20
CHECKED Nov 16 '99 K. Kusumoku	名称 ハンドセット (ブラケット付)
APPROVED Nov 16 '99 K. Kusumoku	外寸図
SCALE 1/2	NAME HANDSET W/ BLACKET
MASS ±10% 0.65 kg	OUTLINE DRAWING
DWG. No. C5603-G06- D	

表 1 TABLE 1

寸法区分 (mm) DIMENSIONS	公差 (mm) TOLERANCE
$L \leq 50$	± 1.5
$50 < L \leq 100$	± 2.5
$100 < L \leq 500$	± 3

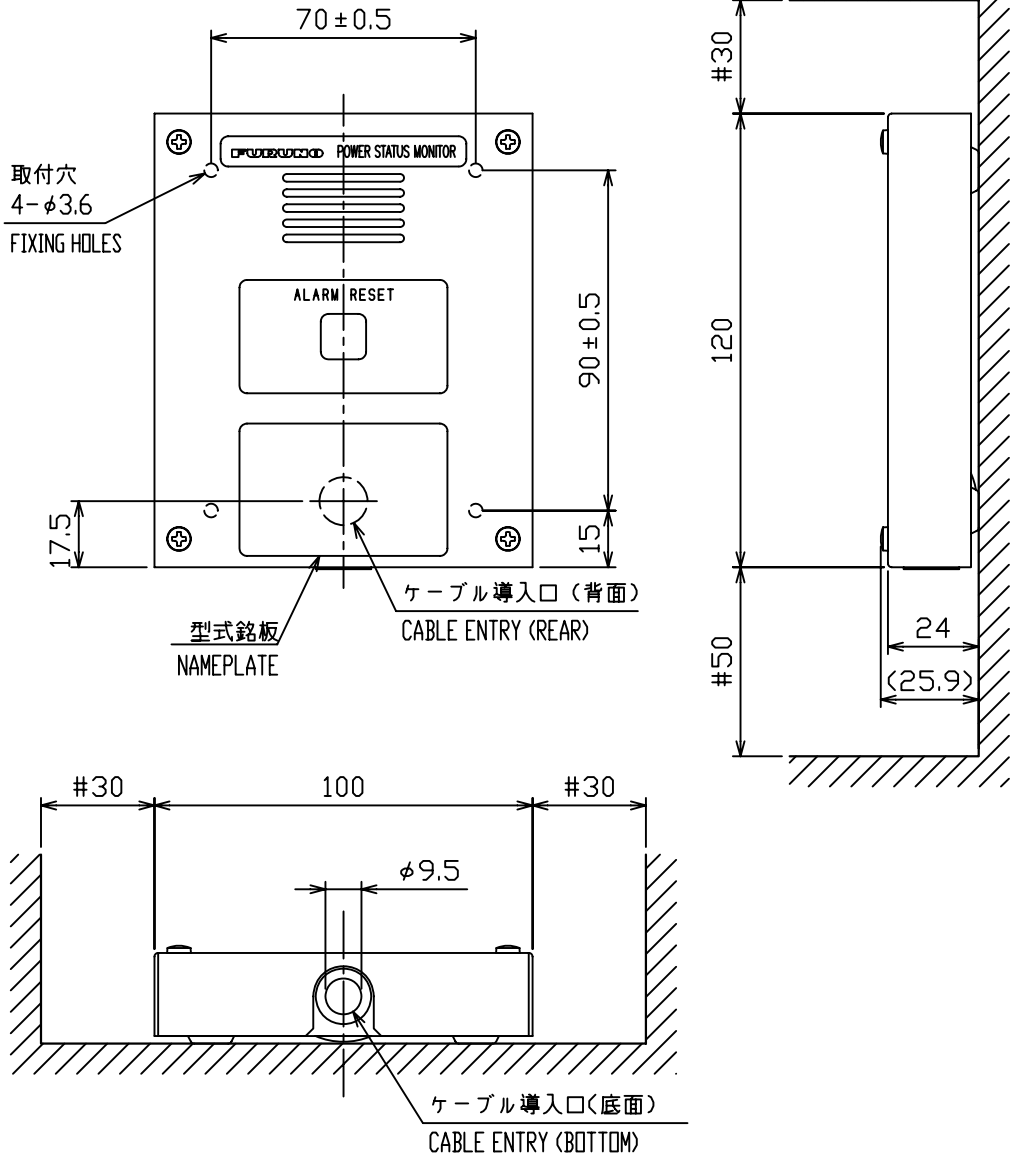

注 記 1) #印寸法は最小サービス空間寸法とする。
2) 指定外の寸法公差は表1による。

NOTE 1. #: MINIMUM SERVICE CLEARANCE.
2. TABLE 1 INDICATES TOLERANCE OF DIMENSIONS WHICH IS NOT SPECIFIED.

DRAWN Nov. 20, '06 E. MIYOSHI	TITLE PSM-01
CHECKED TAKAHASHI, T	名称 パワーステータスマニター
APPROVED Y. Hatai	FS-5070 FS-1570/2570 外寸図
SCALE 1/2	NAME POWER STATUS MONITOR
MASS 0.33 kg $\pm 10\%$	OUTLINE DRAWING
DWG.No. C5636-G05-B	REF.No. 05-087-196G-0



表 1 TABLE 1

寸法区分 (mm) DIMENSION	公差 (mm) TOLERANCE
L ≤ 50	±1.5
50 < L ≤ 100	±2.5
100 < L ≤ 500	±3

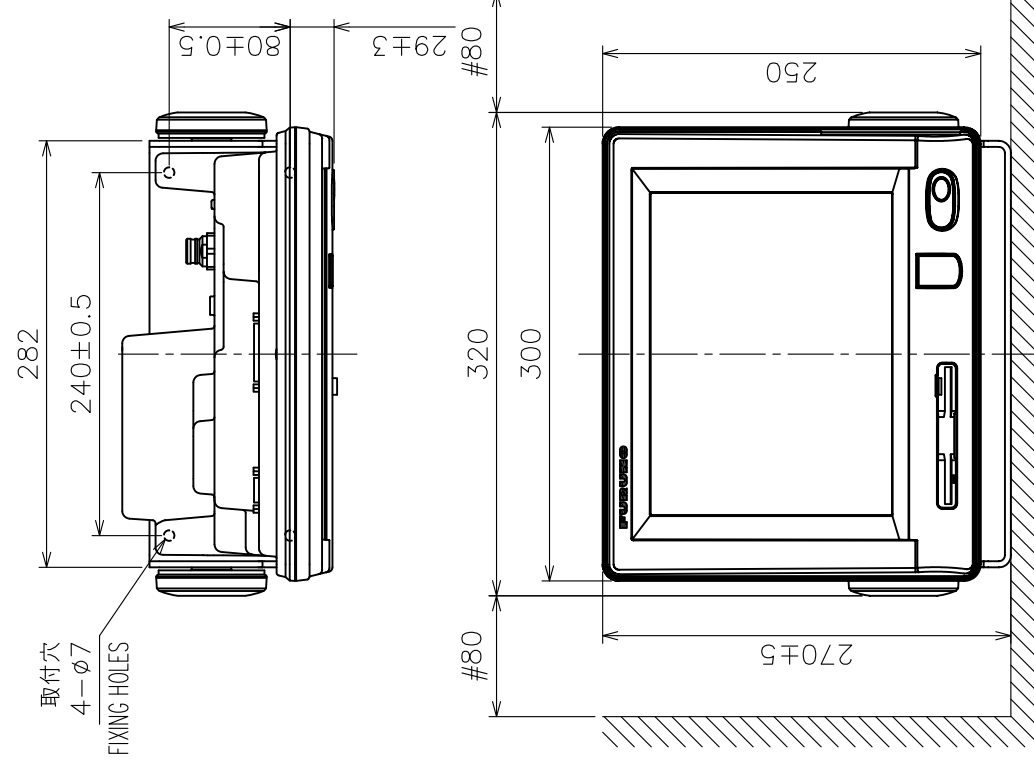
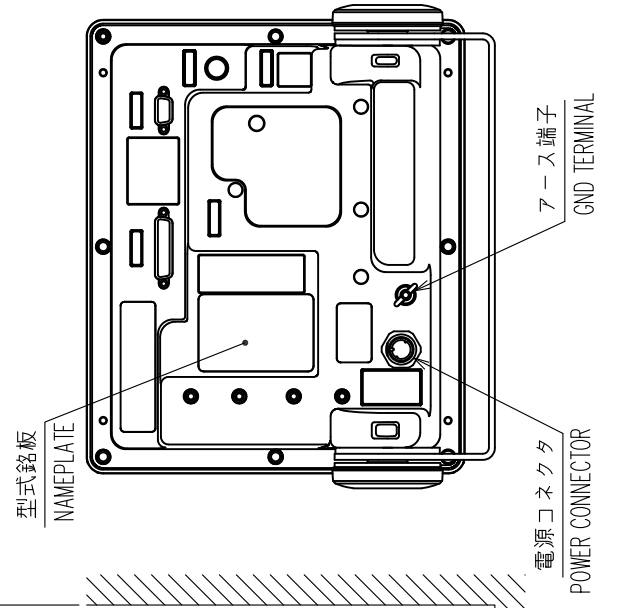

- 注記 1) 指定外の寸法公差は表 1 による。
 2) #印寸法は最小サービス空間寸法とする。
 3) 取付用ネジはトラスタツピンネジ呼び径5×20を使用のこと。
- NOTE 1. TABLE 1 INDICATES TOLERANCE OF DIMENSIONS WHICH IS NOT SPECIFIED.
 2. # MINIMUM SERVICE CLEARANCE.
 3. USE TAPPING SCREWS $\phi 5 \times 20$ FOR FIXING THE UNIT.

DRAWN	8/Jun/09	T.YAMASAKI	TITLE	IB-583
CHECKED	8/Jun/09	T.TAKENO	名称	ターミナル部 (卓上装備)
APPROVED	18/June/09	R. Esumi	外寸図	
SCALE	1/5	MSS 4.1 ±10%	NAME	TERMINAL UNIT (TABLETOP MOUNT)
DWG. No.	C5636-606-C		REF. No.	05-089-600G-4

表 1 TABLE 1

寸法区分 (mm) DIMENSION	公差 (mm) TOLERANCE
L ≤ 50	±1.5
50 < L ≤ 100	±2.5
100 < L ≤ 500	±3

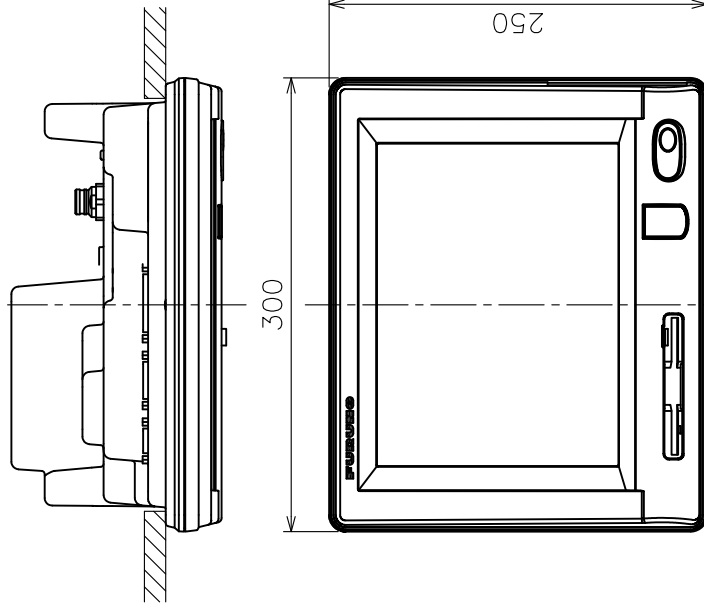

型式銘板
NAMEPLATE

- 注 記
- 1) 指定外の寸法公差は表 1 による。
 - 2) # 印寸法は最小サービス空間寸法とする。
 - 3) 取付用ネジは、セムスネジ B M4x2.0 を使用のこと。
壁の厚さ (A) は $1.1 \leq A \leq 1.4$ とする。それ以外の壁に
装備する場合、使用するネジ長さは $(A + 7.8) \pm 2$ とする。
筐体にはネジ部を 8mm 以上入れないこと。(B ≤ 8)
- NOTE
1. TABLE 1 INDICATES TOLERANCE OF DIMENSIONS WHICH IS NOT SPECIFIED
 2. # MINIMUM SERVICE CLEARANCE.
 3. USE SEMS SCREWS M4x2.0 FOR FIXING THE UNIT.
THICKNESS A: $1.1 \leq A \leq 1.4$ OR SCREW LENGTH: $(A + 7.8) \pm 2$.
DO NOT FASTEN SCREWS INTO UNIT MORE THAN 8 mm.

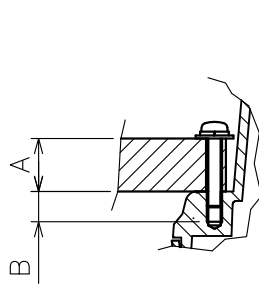

取付ネジ部断面尺度 1/2
DETAIL FOR FASTENING (SCALE 1/2)

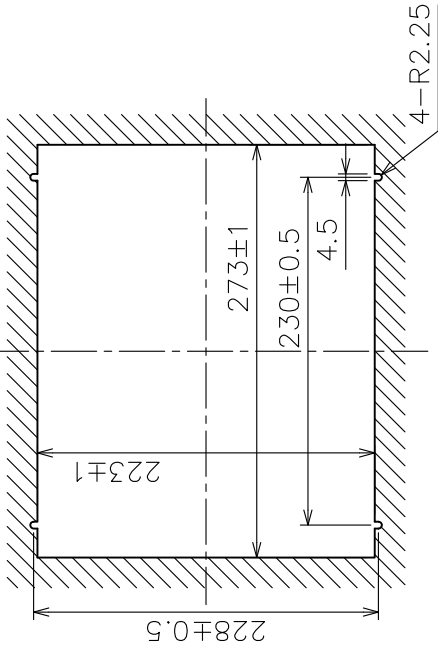
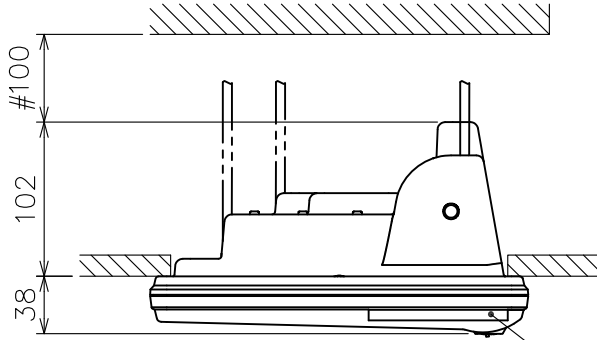

取付寸法図
CUTOUT DIMENSIONS

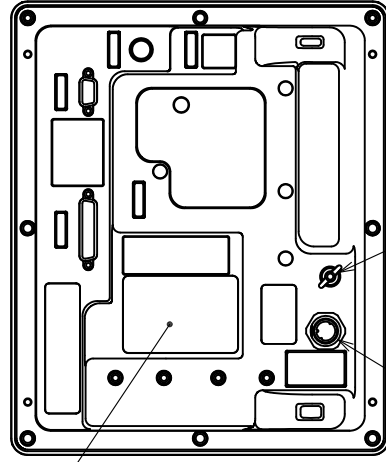

型式銘板
NAMEPLATE

電源コネクタ
POWER CONNECTOR

7-ース端子
7-PIN TERMINAL

DRAWN	8/Jun/09 T. YAMASAKI	TITLE	IB-583
CHECKED	8/Jun/09 T. TAKENO	名称	ターミナル部 (埋込装備)
APPROVED	18/June/09 R. Esumi	外寸図	
SCALE	1/5 MASS 3.5 ±10% kg	NAME	TERMINAL UNIT (FLUSH MOUNT)
DWG. No.	C5636-G07-C	REF. No.	05-089-610G-4

A

注意：
アンテナ線を、給電点より上方に固定する場合は、アンテナ取付台からの距離は1000mm以下とすること。

CAUTION:
WHEN THE ANTENNA CABLE IS FIXED ABOVE THE FEEDING POINT, THE DISTANCE FROM ANTENNA BASE MUST BE WITHIN 1000 mm.

シンプル
シャックル
ワイヤクリップ
THIMBLE
SHACKLE
WIRE CLIP

1000 MAX.

B

アンテナ線 (2m以上)
ANTENNA WIRE
(2m OR MORE)

シンプル
シャックル
碍子
ワイヤクリップ
THIMBLE
SHACKLE
INSULATOR
WIRE CLIP

銅板 (切片)
COPPER STRAP
(A SECTION)

ワイヤクリップ
WIRE CLIP

固定用線
(支給ケーブルを一部切断)
FIXING WIRE
CUT OFF A PART
FROM CABLE SUPPLIED

C

注記

- 1) インマルサットアンテナまでの距離は5m以上とすること。
- 2) アンテナ基部からチューナーまでケーブルを引くときは、必ず絶縁した状態で、できる限り垂直になるようにする。水平面となす角が45度以下とならないこと。
- 3) ホイップアンテナは少なくとも1m以上他の導体構造物から離して船体上部に設置すること。

NOTE

1. DISTANCE TO THE INMAR-ANTENNA SHOULD BE MORE THAN 5m.
2. THE DOWN LEAD FROM THE BASE OF THE ANTENNA TO THE ANTENNA TUNER SHOULD BE INSULATED AND RUN VERTICALLY AS POSSIBLE AND NOT LESS THAN 45° TOWARDS THE HORIZONTAL PLANE.
3. WHIP ANTENNAS SHOULD BE LOCATED IN AN ELEVATED POSITION ON THE SHIP AT LEAST 1m AWAY FROM CONDUCTIVE STRUCTURES.

D

銅板
COPPER STRAP

DRAWN	20/May/2011 T.YAMASAKI	TITLE	WHIP ANTENNA
CHECKED	20/May/2011 H.HAYASHI	名称	ホイップアンテナ組立工材 装備例
APPROVED	20/MAY/2011 R. ESUMI		装備要領
SCALE	MASS ±10% kg	NAME	WHIP ANTENNA LEAD-IN KIT (FOR REFERENCE)
DWGNo.	C5023-Y01-J		INSTALLATION PROCEDURE

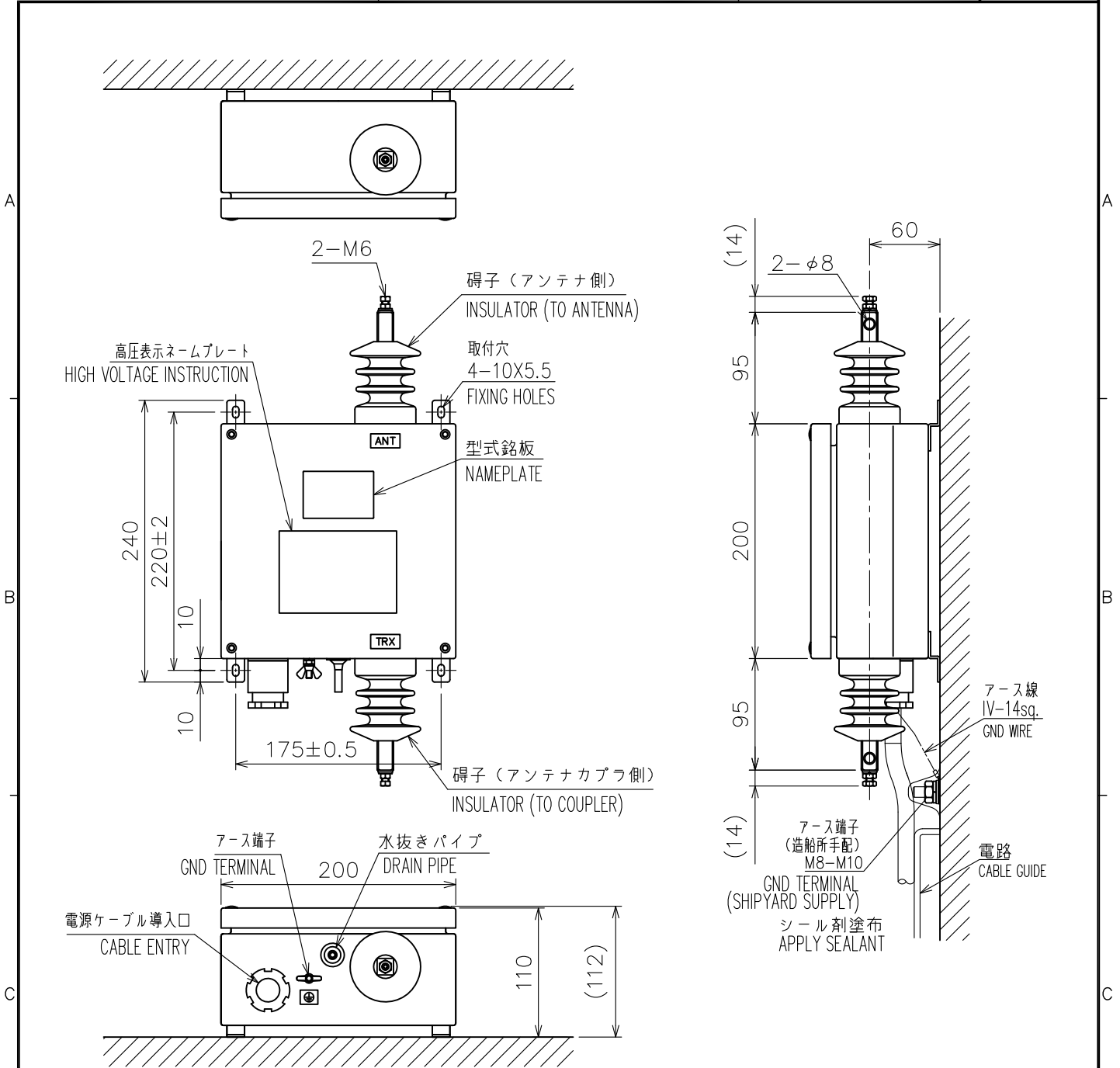

注 記

- 1) 指定外の寸法公差は表 1 による。
- 2) アンテナ及びアンテナカプラに繋げる線については十分な空間を確保すること。
- 3) 取付用ネジはトラスタップピンネジ 呼び径5×20を使用のこと。

NOTE

1. TABLE 1 INDICATES TOLERANCE OF DIMENSIONS WHICH IS NOT SPECIFIED.
2. KEEP SUFFICIENT CLEARANCE TO CONNECT THE WIRES TO ANTENNA AND COUPLER.
3. USE TAPPING SCREWS $\phi 5 \times 20$ FOR FIXING THE UNIT.

表 1 TABLE 1

寸法区分 (mm) DIMENSION	公差 (mm) TOLERANCE
$L \leq 50$	±1.5
$50 < L \leq 100$	±2.5
$100 < L \leq 500$	±3

DRAWN	11/Sep/09 T.YAMASAKI	TITLE	AS-102
CHECKED	11/Sep/09 T.TAKENO	名称	自動アンテナ切換器
APPROVED	25/Sep/09 R.Esumi	FS-1570/2570/5070	外寸図
SCALE	1/5	MASS	3.2 ±10% kg
DWG. No.	C5656-G04-A	REF. No.	05-094-400G-1
		NAME	
		ANTENNA SWITCH	
		OUTLINE DRAWING	

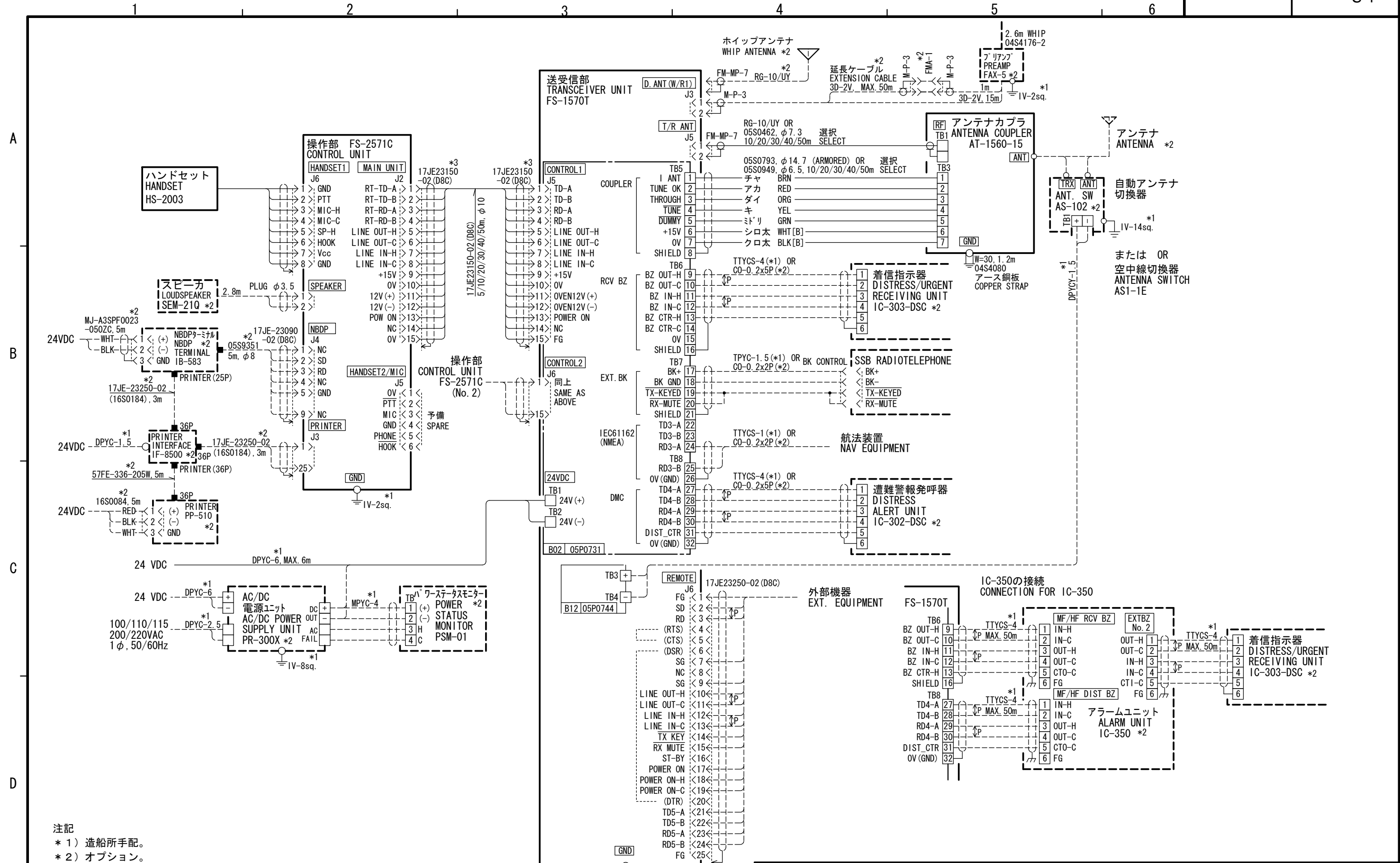

注記
 * 1) 造船所手配。
 * 2) オプション。
 * 3) コネクタは工場にて取付済み。

NOTE
 *1. SHIPYARD SUPPLY.
 *2. OPTION.
 *3. CONNECTOR PLUGS FITTED AT FACTORY.

CO-0. 2x2P: CO-SPEVV-SB-C 0. 2x2P, φ 10.5
 CO-0. 2x5P: CO-SPEVV-SB-C 0. 2x5P, φ 13.5

DRAWN	16/Sep/09 T. YAMASAKI	TITLE	FS-1570
CHECKED	16/Sep/09 T. TAKENO	名称	SSB送受信機
APPROVED	25/Sep/09 R. Esumi		相互結線図
SCALE	MASS kg	NAME	SSB RADIOTELEPHONE
DWG No.	C5636-C01- L		INTERCONNECTION DIAGRAM

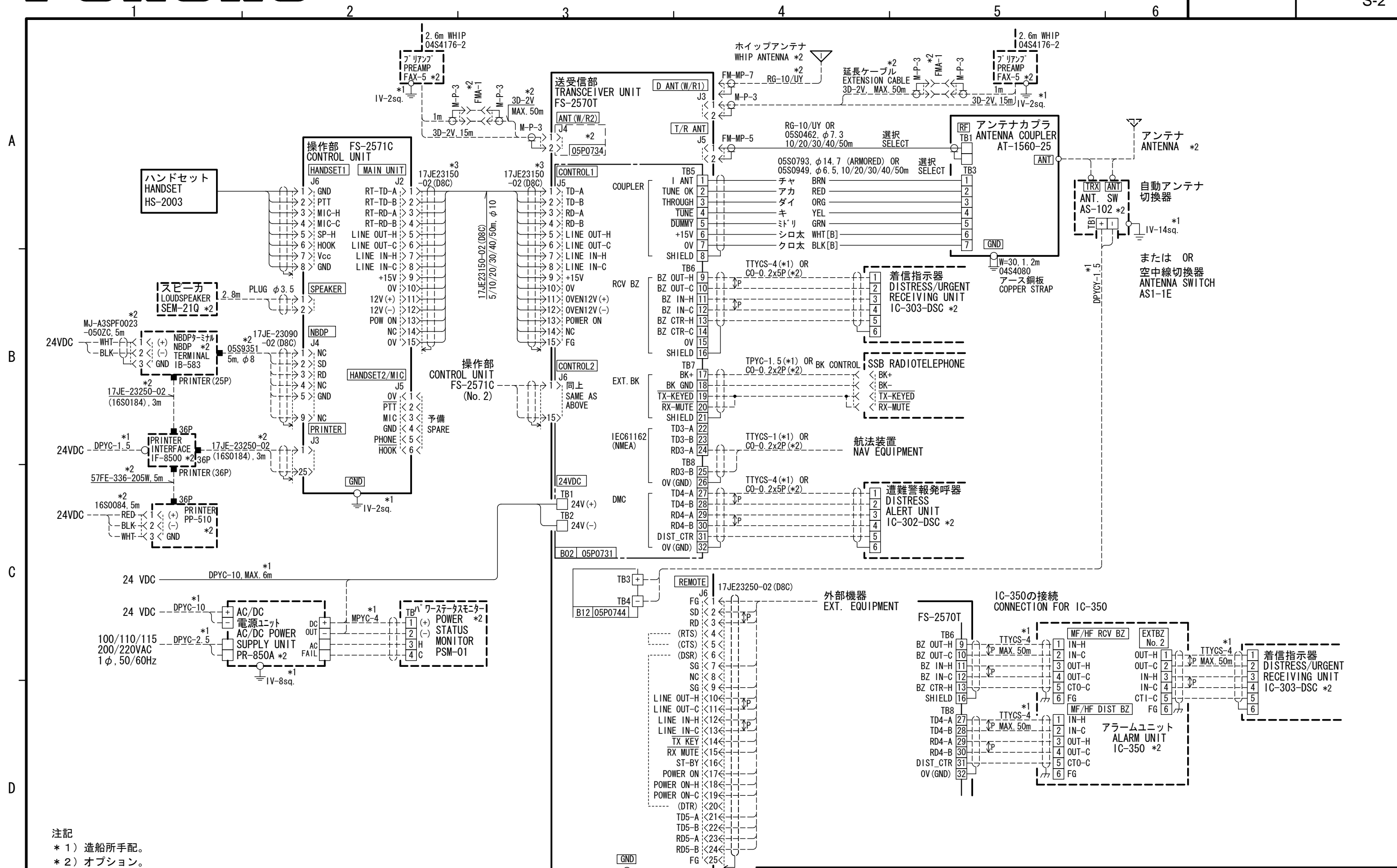

注記
 * 1) 造船所手配。
 * 2) オプション。
 * 3) コネクタは工場にて取付済み。

NOTE
 *1. SHIPYARD SUPPLY.
 *2. OPTION.
 *3. CONNECTOR PLUGS FITTED AT FACTORY.

CO-0. 2x2P: CO-SPEVV-SB-C 0. 2x2P, φ 10.5
 CO-0. 2x5P: CO-SPEVV-SB-C 0. 2x5P, φ 13.5

DRAWN	16/Sep/09 T. YAMASAKI	TITLE	FS-2570
CHECKED	16/Sep/09 T. TAKENO	名称	SSB送受信機
APPROVED	25/Sep/09 R. Esumi		相互結線図
SCALE	MASS kg	NAME	SSB RADIOTELEPHONE
DWG. No.	C5637-C01- L		INTERCONNECTION DIAGRAM